

ASA HIMAS ARCHITECTURAL GLASS



**ASA HIMAS**  
AGC Group

# ARCHITECTURAL GLASS

## **PT ASA HIMAS FLAT GLASS Tbk.**

### **JAKARTA FACTORY**

Jl. Ancol IX/5 Ancol Barat, Jakarta 14430, Indonesia  
Phone +62-21 690 4041 (8 lines)  
Fax. +62-21 690 0470, 691 8709

### **SIDOARJO FACTORY**

Desa Tanjung Sari, Kec. Taman, Kab. Sidoarjo, Jawa Timur 61257, Indonesia  
Phone +62-31 788 2383-84, 788 2901-03  
Fax. +62-31 788 2842, 788 2149

[www.amfg.co.id](http://www.amfg.co.id)

# Daftar Isi

## Contents

Daftar Isi	Contents
Profil Perusahaan	<b>1</b> <i>Company Profile</i>
Pendahuluan	<b>3</b> <i>Preface</i>
	<b>PART ONE</b>
	<b>6</b> <i>Indoflot</i>
	<b>8</b> <i>Panasap</i>
	<b>11</b> <i>Stopsol</i>
	<b>14</b> <i>Sunergy</i>
	<b>16</b> <i>Planibel G</i>
	<b>18</b> <i>Indofigur</i>
	<b>20</b> <i>Asahimas Mirror</i>
	<b>24</b> <i>Lacobel</i>
	<b>PART TWO</b>
	<b>26</b> <i>Tempered Glass</i>
	<b>29</b> <i>Laminated Safety Glass</i>
	<b>32</b> <i>Curved Glass</i>
	<b>34</b> <i>Curtain Wall</i>
	<b>37</b> <i>Glacade</i>
	<b>PART THREE</b>
	<b>51</b> <i>1. General Properties</i>
	<b>52</b> <i>2. Technical Characteristic</i>
	<b>55</b> <i>3. Thermal Crack of Window Glass</i>
	<b>56</b> <i>4. Wind Pressure Resistance Strength</i>
	<b>59</b> <i>5. Impact Strength and Safety</i>
	<b>60</b> <i>6. Glass Balustrade-SS System</i>
	<b>63</b> <i>7. Sound Insulation</i>



AGC Group

# Profil Perusahaan

## Company Profile

Nama Perusahaan **PT Asahimas Flat Glass Tbk** *Company Name*

Status **PMA (Penanaman Modal Asing) Foreign Investment Company** *Status*

Alamat Kantor / Pabrik *Address of Head Office / Factory*

### JAKARTA

Jl. Ancol IX No.5 Ancol Barat  
Jakarta 14430, Indonesia  
Phone : +62 - 21 - 6904041 (8 lines)  
Fax : +62 - 21 - 6918709, 6900470  
PO BOX : 4344/JKT F

### SURABAYA

Desa Tanjung Sari, Kecamatan Taman  
Kabupaten Sidoarjo, 61257  
Jawa Timur, Indonesia  
Phone : +62 - 31 - 7882383 (4 lines)  
Fax : +62 - 31 - 7882842, 7882149  
PO BOX : 1481/SBY 60014

### CIKAMPEK

Bukit Indah Industrial Park (BIIP)  
Sektor 1 A Blok J-L, Cikampek 41373  
Jawa Barat, Indonesia  
Phone : +62 - 264 - 351711 (8 lines)  
Fax : +62 - 264 - 351710

Luas Area **112.5 Ha** *Total Area*

Perkembangan Produksi *Production Activity*

#### **Tungku I Jakarta (Proses Fourcault)**

Pembangunan : Januari 1972  
Mulai Produksi : 26 April 1973

#### **Jakarta Tank Furnace I (Modified FourCault Process)**

Construction : January 1972  
Start Production : April 26, 1973

#### **Tungku II Jakarta (Proses Fourcault)**

Pembangunan : Oktober 1976  
Mulai Produksi : November 1977

#### **Jakarta Tank Furnace II (Modified FourCault Process)**

Construction : October 1976  
Start Production : November 1977

#### **Tungku III Jakarta (Proses Float)**

Pembangunan : April 1981  
Mulai Produksi : Januari 1983

#### **Jakarta Tank Furnace III (Modified Float Process)**

Construction : April 1981  
Start Production : January 1983

#### **Tungku IV Jakarta (Proses Float)**

Pembangunan : Oktober 1990  
Mulai Produksi : Februari 1993

#### **Jakarta Tank Furnace IV (Modified Float Process)**

Construction : October 1990  
Start Production : February 1993



**Pabrik Kaca Pengaman, Jakarta**

Pembangunan : April 1975  
 Mulai Produksi : Mei 1976

**Jakarta Safety Glass Factory**

Construction : April 1975  
 Start Production : May 1976

**Tungku I Surabaya (Proses Float)**

Pembangunan : Juli 1985  
 Mulai Produksi : Maret 1987

**Surabaya Tank Furnace I (Modified Float Process)**

Construction : July 1985  
 Start Production : March 1987

**Proses Cermin**

Pembangunan : Juni 1985  
 Mulai Produksi : Januari 1986

**Mirror Line**

Construction : June 1985  
 Start Production : January 1986

**Tungku II Surabaya**

Pembangunan : Januari 1996  
 Mulai Produksi : Juli 1997

**Surabaya Tank Furnace II (Modified Float Process)**

Construction : January 1996  
 Start Production : July 1997

**Pabrik Kaca Pengaman Cikampek**

Pembangunan : Maret 1997  
 Mulai Produksi : Februari 1998

**Cikampek Safety Glass Factory**

Construction : March 1997  
 Start Production : February 1998

Merger (AMS, Danta & PSI)

**May 1991**

Merger (AMS, Danta & PSI)

Modal Dasar

**Rp 300.000.000.000,-**

Basic Capital

Jumlah karyawan

**3.159**

Number of Emploess

Produksi yang diizinkan

Authorized Capacity

**Kaca Lembaran : 570.000 Ton**

**Flat Glass : 570.000 Ton**

**Kaca Cermin : 1.200.000 m<sup>2</sup>**

**Mirror Glass : 1.200.000 m<sup>2</sup>**

**Kaca Pengaman : 3.400.000 m<sup>2</sup>**

**Safety Glass : 3.400.000 m<sup>2</sup>**



# Pendahuluan

## Preface

Keberadaan kaca sebagai bahan bangunan telah dikenal dan digunakan sejak dibutuhkan bidang transparan yang mampu menyatukan ruang luar dengan ruang dalam serta memasukan unsur pencahayaan alami namun tetap menjaga kondisi ruang dalam dari pengaruh ruang luar.

PT Asahimas Flat Glass Tbk. sebagai perintis industri kaca di Indonesia sejak 1973, telah ikut serta aktif dalam memenuhi kebutuhan diatas sesuai dengan lajunya pembangunan di Indonesia.

### Sejarah kaca

Pembuatan kaca sendiri berawal dari daerah sekitar Mesopotamia, 7 ribuan tahun yang lalu. Benda-benda terbuat dari kaca banyak ditemukan bersamaan dengan perhiasan mewah yang terbuat dari logam mulia dan batu berharga. Sedangkan kaca sebagai bahan bangunan mulai digunakan setelah kaca lembaran dapat dibuat secara massal di Roma, yaitu sekitar tahun 30 sebelum masehi sampai dengan tahun 345 masehi dengan teknik yang disebut sebagai teknik tiup. Meskipun kaca lembaran yang dihasilkan berukuran kecil dan dengan mutu yang kurang baik, namun teknik tiup ini tetap dipakai hingga abad XVII.

Baru pada awal abad XX, teknik ini mengalami mekanisasi sehingga dapat menghasilkan kaca lembaran yang berukuran lebih besar. Metode berikutnya yang dikembangkan adalah suatu proses dimana cairan kaca yang masih membara ditarik terus menerus dari tungku peleburan melalui sejumlah rol. Kaca lembaran yang dihasilkan dengan metode ini ("Slit Method") memiliki permukaan yang kurang rata dan menyebabkan distorsi terhadap arah pandangan.

*Glass is well known as one of the integral building material, one that can blend interior with exterior, and the same time keeps the two apart.*

*PT Asahimas Flat Glass Tbk. is the pioneer of the Indonesian glass industry which was established in 1973. The company is proud to do its share in the role of stimulating Indonesian development.*

### History of Glass

*Making glass dates back to Mesopotamia, 7,000 years ago. An abundance of glass wares has been found along with jewelleries made of pure gold and precious stones. The use of glass as a building material dates back to ancient Rome about 30 BC to 345 AD. At that time the glass was being blown in to shape. This technique was used for the production of windows only, produced low quality small size sheets, but still this was the method used until the seventeenth century.*

*The twentieth century saw this technique improve to produce a much larger glass sheet. A subsequent method was the "Slit Method" which had the molten glass being drawn continuously from the furnace through rollers. This produced slightly uneven surface with some distortion.*

Mutu ini cukup memadai untuk kaca-kaca jendela, tapi untuk menghasilkan mutu yang lebih tinggi, maka kedua permukaan kaca ini perlu dipoles hingga rata, halus dan mengkilap. Hal ini biasa dilakukan untuk kaca cermin dan berharga sangat mahal.

*This is quite acceptable for window glass, but in order to achieve the highest quality of glass, both surfaces of the glass should be polished to achieve perfect flatness, smoothness and shine. This process is only applied to the making of mirrors and quite costly.*

Baru pada tahun 1959, Pilkington berhasil menciptakan suatu proses baru yang disebut "Float Process" yang dapat menghasilkan kaca bermutu prima, kedua permukaannya rata sempurna dan bebas distorsi.

*In 1959, Pilkington invented the "Float Process" which revolutionized glass making with superb quality for both surface, produced of perfect flatness and free from distortion.*

Proses selanjutnya dikembangkan oleh beberapa negara, salah satunya Jepang oleh Asahi Glass Co., Ltd hingga menjadi suatu teknologi pembuatan kaca lembaran yang sempurna dan canggih. Dari Asahi Glass Co., Ltd inilah Indonesia mengenal teknologi pembuatan kaca lembaran dan melalui kerjasama dengan Rodamas Co., Ltd membentuk PT Asahimas Flat Glass, Tbk. sebagai perintis industri kaca pertama di Indonesia.

*Then the float process was developed by other countries such as Japan through Asahi Glass Co., Ltd which turn one technology into perfect and advanced glass sheet manufacturing. Through Asahi Glass Co., Ltd Indonesia acknowledged the technology of glass sheet manufacturing and established a joint venture with Rodamas Co.,Ltd to perform PT Asahimas Flat Glass, Tbk. as the first Indonesia sheet glass industry.*





Secara prinsip float process (proses pengambangan) dapat diceritakan sebagai berikut: campuran bahan baku kaca setelah dilebur dalam tungku (melting furnace) pada suhu  $\pm 1.700^{\circ}\text{C}$  dialirkan ke dalam bak yang berisi cairan timah dan diambangkan diatas cairan timah tersebut (float bath). Pada ujung lain, cairan kaca yang mulai mengental ( $\pm 1.100^{\circ}\text{C}$ ) ditarik keluar dari float bath dan didinginkan secara perlahan-lahan dalam terowongan pendingin (annealing lehr) hingga suhu  $\pm 70^{\circ}\text{C}$  dan siap dipotong sesuai ukuran yang ditentukan.

Karena sifat cairan itu sendiri yang selalu memiliki permukaan rata, maka kaca yang dihasilkan dengan proses pengambangan (cairan) ini merupakan kaca lembaran dengan mutu tinggi, permukaannya rata sejajar dan bebas distorsi. Hasil kaca ini disebut dengan Float Glass.

Dengan makin meningkatnya kebutuhan akan kaca, maka tuntutan akan kaca tidak lagi hanya sekedar sebagai bidang transparan saja, tapi berkembang ke arah kebutuhan lain, hingga muncul kaca-kaca berwarna, kaca berpola dan kaca-kaca lainnya. Dalam hal ini PT Asahimas sangat tanggap dalam mengikuti perkembangan tersebut.

*Float process in principle can be described as follows; The process heats the glass to  $\pm 1,700^{\circ}\text{C}$ , the molten glass is poured into a huge tub filled with liquid tin and the glass floats in top of the metal in the float bath. The order ends at  $\pm 1,100^{\circ}\text{C}$  and the hardening glass liquid floats out from the float bath and then being cooled in a cooling tunnel (Annealing Lehr) until the temperature falls to  $\pm 70^{\circ}\text{C}$  and is ready to be cut as required.*

*Due to the flat surface of the liquid, this process creates an exceptionally flat glass sheet, absolutely free from distortion. The result of this glass is called Float Glass.*

*Because of the increasing demand on variety of glass, not only clear glass are needed, but tinted, reflective, patterned glass, etc., PT Asahimas is capable to fullfil the need and demand of the development market.*

Manufacturing Process of Float Glass

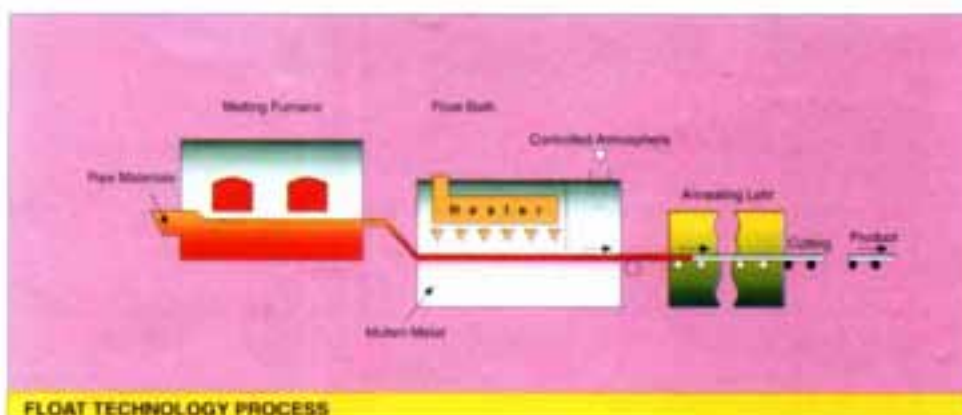



# INDOFLOT

Clear Float Glass with Excellent Transparency and Transmittance

1 Bagian  
Part

Kaca clear dengan transmisi optimal tanpa memberikan efek bayangan, dapat menggabungkan anda secara alami dengan lingkungan sekitar. Indoflot memberikan pencahayaan alami dan keleluasaan melalui pemandangan yang luas dan jelas dihadapan anda. Hal ini memungkinkan anda merasakan kehidupan baru setiap hari. Anda akan melihat perbedaan yang diciptakan oleh Indoflot.

*A clear glass with optimal transmission and gives no shadowing effect, can unite you naturally with surrounding environment. Indoflot provides you with abundant natural light and spaciousness through the wide and clear and view in front of you. It enables you to feel like facing a brand new life everyday. You will notice the difference it makes now.*

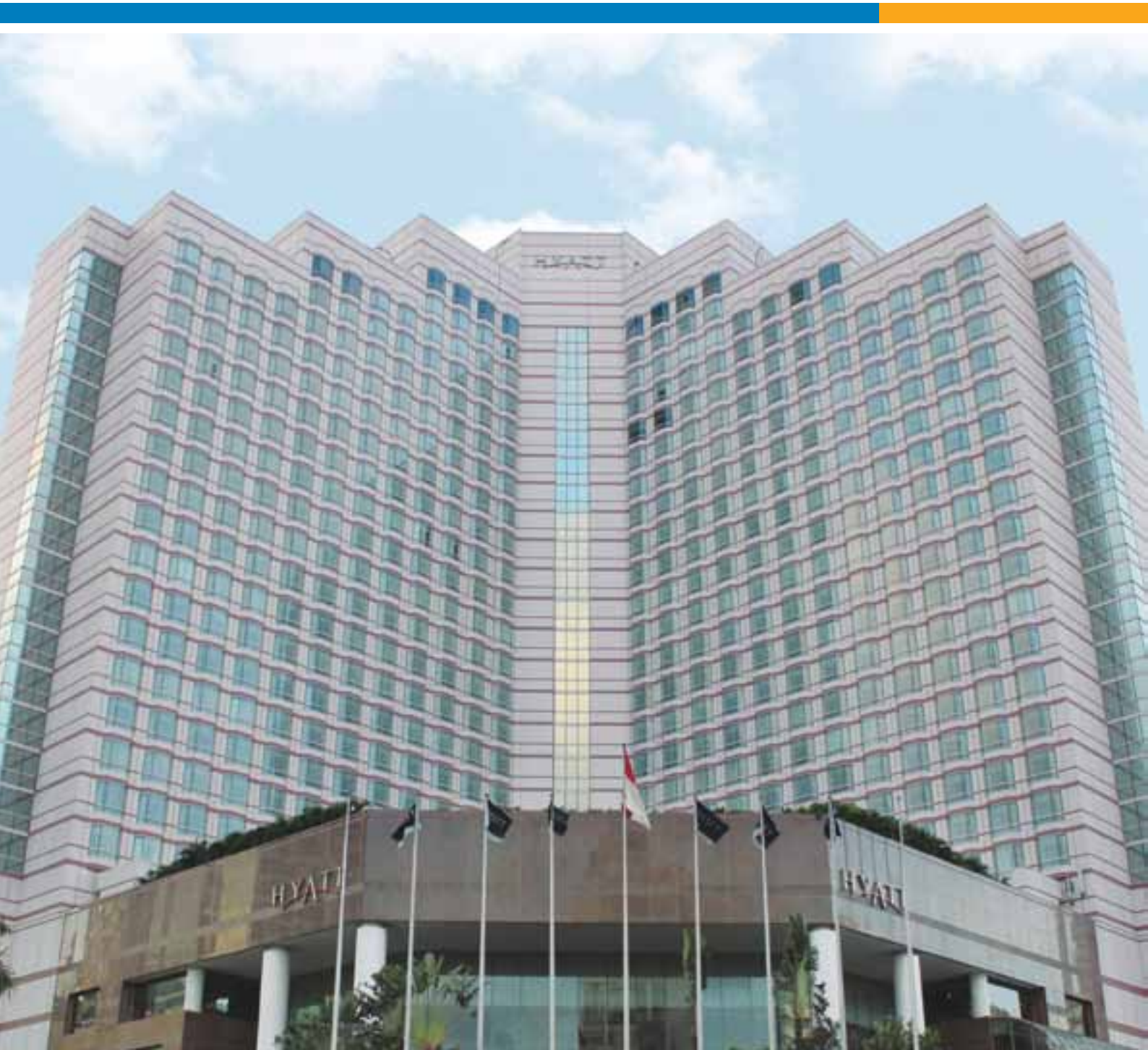



## Karakteristik Umum

- Kaca bening hasil proses pengembangan dengan permukaan yang sangat bersih, rata dan bebas distorsi, memberikan tingkat transmisi yang tinggi (lebih dari 90%) serta memberikan bayangan yang sempurna.
- Ketebalan yang dihasilkan mampu hingga 19mm, dengan lebar 3.00 m dan panjang 10 m (d disesuaikan dengan kemampuan transportasi-nya).
- Dimensi yang besar dan ketebalan yang bervariasi ini memberikan keleluasaan pada perencana bangunan untuk berkreasi dengan dinding-dinding kaca / bukaan-bukaan besar.

## Pemakaian

- Eksterior dan interior pada bangunan, baik untuk rumah tinggal, bangunan umum, perkantoran, pertokoan, bangunan tinggi dan lain-lain.
- Lemari pajang, perabot rumah tangga, table top, dinding dekorasi, aquarium, cermin dan lain-lain.
- Kaca-kaca pengaman dan pemakaian khusus.
- Dinding kaca berbagai jenis, termasuk dinding-dinding yang besar (Suspension Glass System).

## Features

- *Transparent float glass, made by the float process, has a high-precision of flatness (smooth surface), free of distortion, fine transmission (above 90%) or perfect images reflection.*
- *Thickness up to 19 mm is possible with width of about 3 m and length of about 10 m (which is sectioned for ease of transportation).*
- *This large dimension allows designers to use their creativity in planning glass wall buildings and wide buildings and wide opening windows.*

## Applications

- *Exterior and interior of residential houses, public buildings, offices, shopping malls, skyscrapers, etc.*
- *Showcases, show-windows, cupboards, table tops, decorative friezes, aquariums, mirrors, etc.*
- *Safety glass and special usage.*
- *Many kinds of glass walls, including Suspension Glass System.*

### Jenis dan Spesifikasi

### Type and Specifications

PRODUCT NAME	TYPES	THICKNESS		Weight (kg/m <sup>2</sup> )	MANUFACTURING SIZE (inch)														
		STANDARD (mm)	TOLERANCE (mm)		Max Standard Size														
					44x36	48x20	48x24	48x34	50x30	60x48	72x36	72x48	72x52	80x36	80x40	96x72	144x96	120x84	
INDOFLOT  Clear Float Glass	FL2	2	1.8 - 2.2	5	✓	✓	✓	✓	✓										
	FL3	3	2.8 - 3.2	7						✓	✓	✓							
	FL4	4	3.8 - 4.2	10						✓		✓		✓			✓	✓	
	FL5	5	4.8 - 5.2	12						✓		✓	✓	✓	✓		✓	✓	
	FL6	6	5.8 - 6.2	15														✓	✓
	FL8	8	7.7 - 8.3	20														✓	✓
	FL10	10	9.7 - 10.3	25														✓	✓
	FL12	12	11.7 - 12.4	30														✓	✓
	FL15	15	14.5 - 15.6	37															✓
	FL19	19	18.2 - 19.4	47															✓





AGC Group

# PANASAP

Solar Heat Absorbing Colored Glass that Creates a Comfortable Room

Panasap merupakan kaca float yang diberi warna dengan menambahkan sedikit logam pewarna seperti kobalt, besi, selenium dan lain-lain pada bahan baku kaca.

*Panasap is float glass with a tint, made by adding metals like cobalt, manganese, selenium, etc.*



## Karakteristik Umum

- Dengan pemberian warna, Panasap akan mempunyai kemampuan untuk menyerap sebagian panas matahari (rata-rata daya serapnya 55%) sehingga akan mengurangi beban pendingin ruangan dan memberikan rasa nyaman pada penghuni bangunan.
- Warna Panasap yang tersedia: Panasap Dark Blue, bersih dan terang; Panasap Euro Grey dan Dark Grey, anggun dan santai; Panasap Bronze, indah keemasan dan Panasap Green, Blue Green, tenang dan alami.
- Karena kemampuan meneruskan cahaya dari Panasap (rata-rata 45%) jauh lebih rendah dari indoflot, maka cahaya-cahaya yang menyilaukan akan dapat dikurangi menjadi lebih lembut dan sifat daya tembus pandangnya menjadi rendah, sehingga sepanjang hari, dimana tingkat penerangan di luar lebih terang dibandingkan di dalam bangunan, kaca Panasap ini dapat melindungi kebebasan pribadi penghuninya.

## Pemakaian

- Eksterior berbagai bangunan dari rumah tinggal, hingga bangunan tinggi, baik sekitar jendela kaca ataupun sebagai pelindung kaca
- Interior : perabotan, partisi dan lain-lain
- Dekorasi-dekorasi lainnya

## Catatan

- Makin tebal kaca Panasap, warna akan semakin gelap dan tingkat penyerapan panasnya akan semakin tinggi. Untuk hal ini maka perlu sekali untuk memberikan pengawasan yang cukup ketika pemasangan dan perawatan.
- Untuk penggunaan Panasap dimana kemungkinan retak karena temperature mudah terjadi, terutama (Panasap Dark Grey) mohon diperhatikan ketebalan kaca yang digunakan atau hubungi kami untuk konsultasi.
- Dalam pemotongan kaca, harus dihasilkan potongan yang baik dan bersih, bebas dari chipping (goresan/gompel) dan kemudian perlu digosok tepinya dengan sander pada tingkat 120 mesh atau lebih.
- Harus diusahakan agar kaca yang terpasang pada rangkanya tidak bersentuhan langsung dengan rangkanya.
- Hindari outlet AC yang langsung meniupkan udara dingin ke bidang kaca secara terus menerus.
- Hindarkan persinggungan langsung kaca dengan tirai atau penempatan perabotan yang menempel pada dinding kaca yang dapat menimbulkan akumulasi panas.
- Bersihkan kaca secara rutin 2-3 bulan sekali pada daerah dengan polusi udara tinggi atau bila terkena air semen setiap 1 bulan sekali untuk mencegah terjadinya efek alkaline.

## Features

- *Panasap can absorb up to 55% of the sun's heat, resulting in cost savings for air conditioned, and more satisfaction and comfortable tenants.*
- *Panasap is available in the following colours, i.e: Panasap Dark Blue, clean and bright; Panasap Euro Grey and Dark Grey, elegant and relaxing; Panasap Bronze, golden beauty effect; Panasap Green, Blue Green calm and natural.*
- *Due to its light deflecting ability (45%) the fierce blinding ray of the sun is reduced and softened during the daytime.*

## Applications

- *Exterior of such as types of buildings.*
- *Interior such as furniture, partitions, etc*
- *Other decorative purpose*

## Notes

- *The thicker the Panasap Glass is, the darker the colour becomes and the higher the heat absorptions becomes. This sometimes makes Panasap easier to be cracked by the heat than indoflot. The extra attention must be taken during installation and maintenance.*
- *Extreme temperature may crack Panasap, especially Panasap Dark Grey, please take special attention to its thickness or contact us for consultation*
- *When cutting the glass, clean cut should be applied as a rule. The edge of corrections has to be polished after cutting, use a sander of 120 mesh or above.*
- *During installation, glass sheets must not attach directly to frames (in direct contact).*
- *Avoid direct air conditioned air blow at the glass surface.*
- *Be careful not to fix a thick curtain or place lockers, furniture, etc, closely to the glass in the room : otherwise, that may be accumulated heat which will cause cracks,*
- *Clean the glass periodically (once every 2 or 3 months) or every month if the external wall was contaminated with concrete or mortar to prevent an alkaline effect.*



- Gunakan sealant yang benar-benar elastic dan bermutu baik (Polysulfids ; silicons sealant, dll)
- Gunakan backup material yang memiliki tingkat insulasi panas yang tinggi, seperti neopreme, foam dan polyethylene foam
- Gunakan 2 buah setting blocks atau neoprene dengan kekerasan 90° atau lebih pada sisi bawah kaca, dengan ukuran:

Panjang = (25 x luas kaca dalam m<sup>2</sup>) mm, max 50 mm  
 Lebar = tebal kaca + 5 mm  
 Tebal = 5 mm s/d 12 mm

- Use an elastic sealant of high quality (polysulfide, silicone sealant, etc) as a sealing material.
- Use material of high heat insulation back up such as neoprene, foam and polyethylene foam.
- Use two setting blocks or neoprene, rubber hardness 90° or above, at the base with dimensions specified belows:

Length = (25 x area glass in SQM) mm, max 50 mm  
 Width = Glass thickness + 5 mm  
 Thickness = 5 mm to 12 mm

Glazing

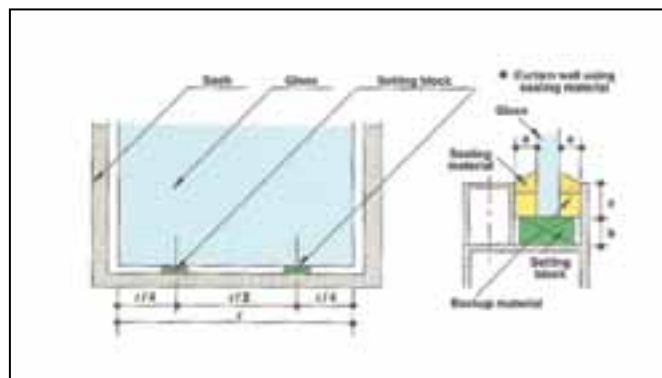

Jenis dan Spesifikasi

Type and Specifications

PRODUCT NAME	TYPES	STANDARD THICKNESS (mm)	MANUFACTURING SIZE (mm)											
			STANDARD SIZE											
			3	5	6	8	12	60 x 48 1524 x 1219	72 x 52 1829 x 1321	80 x 36 2032 x 914	80 x 40 2032 x 1016	96 x 72 2438 x 1829	120 x 84 3048 x 2134	126 x 84 3210 x 2134
PANASAP Tinted Float Glass	Panasap Blue Green	BNFL	✓	✓	✓									5, 6, 8
	Panasap Dark Blue	DHFL	✓	✓	✓	✓	5				5			5, 6, 8, 12
	Panasap Euro Grey	GEFL	✓	✓	✓	✓								5, 6, 8, 12
	Panasap Dark Grey	DGFL	✓	✓	✓		3, 5	5	5	5	5	5		6
	Panasap Bronze	BRFL	✓	✓	✓									5, 6, 8
	Panasap Green	GNFL	✓	✓	✓	✓								5, 6, 8, 12

# STOPSOL



Solar Heat Reflective Glass to Improve Coolness

Stopsol merupakan kaca yang dilapisi dengan pelapis transparan tipis dari oksidasi logam (sebagai lapisan pemantul) melalui proses pyrolysis yang merupakan proses canggih dari teknologi AGC Europe.

*Stopsol is a single sheet glass covered with a thin transparent metal oxide through a process called pyrolysis, a sophisticated result of AGC Europe.*



Lapisan (coating) kaca reflektif ini memiliki daya tahan dan kualitas penampilan yang tetap sepanjang waktu, memantulkan cahaya dan panas serta mampu memberikan penampilan yang mewah, sekaligus menurunkan beban energi pengkondisian udara. Pelapis ini dilapiskan hanya pada satu sisi kaca dan terdiri dari 2 jenis coating yaitu supersilver dan classic.

*This reflective coating has a long lasting endurance and quality, reflects light and heat, and delivers rich touch of style while at the same time reduces air conditioned need. The coating is applied on only one surface of the glass and it consists of supersilver and classic.*

### Karakteristik Umum

- Dengan Pyrolytic coating Stopsol akan tahan terhadap kondisi cuaca, seperti perubahan temperatur udara, polusi/debu-debu dan korosi, membuat warna Stopsol tidak akan memudar dan kehilangan kecemerlangan dari warna aslinya.
- Kedua jenis coating Stopsol dilapiskan pada indoflot dan warna-warna Panasap Dark Blue, Euro Grey, Dark Grey, Blue Green dan Green. Dengan kaca indoflot diperoleh kaca reflective Stopsol yang memantulkan energi/panas matahari yang masuk dan memberikan warna netral. Sedangkan dengan Panasap selain dipantulkan, ada pula panas yang diserap, sehingga jauh lebih hemat lagi terhadap penggunaan energi pengkondisian udara dan memberikan warna-warna menarik.
- Meskipun memantulkan sebagian besar cahaya dan energi matahari, namun masih memiliki transmisi cahaya yang baik, sehingga suasana luar masih bisa dinikmati, tidak silau dan tidak melelahkan mata.
- Stopsol memberikan banyak pilihan untuk mendukung kebebasan rancangan, sangat harmonis baik untuk vision maupun spandrel.
- Posisi lapisan Stopsol dapat ditempatkan baik dibagian dalam bangunan maupun diluar bangunan.

### Features

- *With “Pyrolytic coatings” Stopsol reflective glazing exceptionally resist to harsh environment conditions such as extreme temperature changes, pollutions and corrosions. This special coating ensure a greater stability if appearance and performance overtime, it will never peel off nor lose its brilliance or its original colour.*
- *Stopsol Supersilver and Classic are available in Indoflot (clear) and Panasap colour (Dark Blue, Euro Grey, Dark Grey, Blue Green and Green). With Indoflot, Stopsol will reduce the amount of heat by reflecting it and presenting a new colour. As in Panasap, beside reflecting a light, there is a certain amount of the heat absorption, so it saves more energy for air conditioned while also offers a range of interesting colours.*
- *By reflecting a large amount of sunlight and energy, Stopsol still has a good light transmission capability*
- *Stopsol provides a wide range of freedom design and ideal for vision or spandrels.*
- *Stopsol’s coating can be placed at the inside or outside buildings.*

### Penggunaan

- Untuk buka-bukaan (jendela) yang diharapkan berpenampilan mewah pada bangunan
- Untuk semua tipe dinding kaca

### Applications

- *Windows of high grade and high performance buildings.*
- *For all types of glass walls.*

### Catatan

- Stopsol sangat mungkin untuk penggunaan khusus seperti, insulating, glazing, tempered safety glass, laminated safety glass, walaupun ada sedikit distorsi pada bayangannya.

### Notes

- *If stopsol glasses are processed to tempered safety glasses, laminated safety glass, double glazing units, etc., their reflecting images may be further distored.*

#### Jenis dan Spesifikasi

#### Type and Specifications

PRODUCT NAME	TYPES		STANDARD THICKNESS (mm)			MANUFACTURING SIZE (mm) STANDARD SIZE				WEIGHT (kg/m <sup>2</sup> )
			5	6	8	3210 x 2134	3210 x 2250	3048 x 2134	5100 x 3210	
STOPSOL  Online Reflective Glass	Supersilver Dark Blue	SSDH	✓	✓	✓	5, 6, 8	5, 6, 8		6, 8	
	Supersilver Euro Grey	SSGE		✓	✓	6, 8	6, 8		6, 8	
	Supersilver Green	SSGN	✓	✓	✓	5, 6, 8	5, 6, 8		6, 8	
	Supersilver Blue Green	SSBN		✓	✓	6, 8	6, 8		6, 8	5mm = 12
	Supersilver Clear	SSFL		✓	✓	6, 8	6, 8		6, 8	6mm = 15
	Supersilver Dark Grey	SSDG	✓					5		
	Classic Dark Blue	CDH	✓	✓	✓	5, 6, 8	5, 6, 8		6, 8	8mm = 20
	Classic Green	CGN	✓	✓	✓	5, 6, 8	5, 6, 8		6, 8	



### Glazing

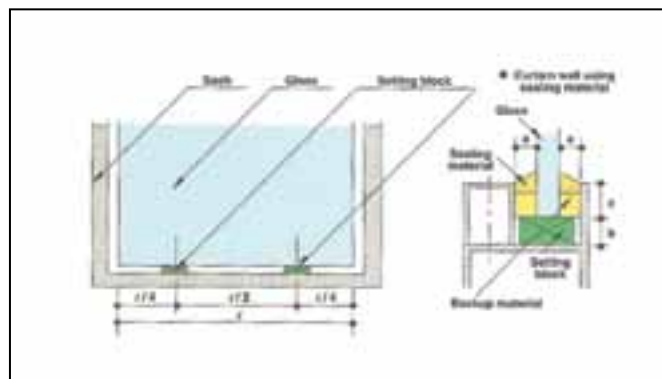

- Ikuti prosedur pemasangan yang benar untuk memperoleh bayangan yang sempurna, dan menghindari thermal cracking.
- Hindarkan permukaan kaca dari semburan udara AC secara langsung dan terus menerus.
- Hindarkan persinggungan langsung dengan tirai secara terus menerus dan hindari dari hal-hal yang menimbulkan akumulasi panas, seperti penempatan perabot.
- Gunakan tempered stopsol dimana kemungkinan terjadi thermal shock dan akumulasi panas sangat tinggi.
- Pada waktu pemotongan, posisi coating harus berada diatas untuk menghindari goresan akibat partikel-partikel sisa pemotongan yang tertinggal pada meja potong. Hasil potongan kaca harus bersih, tanpa cacat (bergerigi).
- Gunakan rangka yang baik dan memiliki presisi yang tinggi, hati-hati ketika membersihkan sealant dengan tinner, aseton, alkohol, atau yang lainnya, segera bersihkan dengan air bersih.
- Bersihkan setiap 2 bulan sekali untuk mendapatkan umur yang panjang dan kecemerlangan refleksi.
- Gunakan air biasa atau neutral detergent (non-abrasive detergent) untuk kotoran-kotoran yang sulit, kemudian cuci segera dengan air biasa kembali. Jangan gunakan pembersih yang berupa bubuk.
- Hindarkan dari pembersih yang berupa cairan kimia untuk dinding keramik, batu dan beton.
- Follow the installation procedure properly, so as to get perfect images and prevent from thermal cracking.
- Avoid direct air conditioned air blow at the glass surface.
- Be careful not to fix a thick curtain or place lockers, furniture etc., closely to the glass in the room; otherwise, that may be accumulated heat which will cause cracks.
- Use tempered Stopsol for possible thermal shock and heat accumulation.
- When cutting the glass clean cut should be applied as a rule. The coating position should be on the top to avoid scratches by the partial left on the cutting table.
- Use high-precision sashes and be careful when removing sealant or grease with thinner, toluene, acetone, alcohol, etc., Be sure to rinse of with water thoroughly afterwards.
- Clean the glass at least once every two months for long live and fine reflecting images.
- Use water for cleaning or a neutral detergent (non-abrasive detergent) if the glass is very dirty, and then wash it with water.
- Be careful not to allow detergent to adhere to the glass when washing curtain walls, tiles, stone, etc.



AGC Group

# SUNERGY

Solar Control Low E-Glass

Sunergy merupakan kaca yang dilapisi 2 pelapis (coating) oksida logam melalui proses CVD (Chemical Vapor Deposition). Pelapis ini dilapiskan hanya pada satu sisi kaca. Adapun 2 pelapis (coating) tersebut: Low Reflective coating dan Low Emissivity coating dapat mengurangi panas yang masuk sehingga mampu meningkatkan kenyamanan.

*Sunergy is a glass product that combines application of two layers of coating, low reflective and low emissivity, through CVD (Chemical Vapor Deposition) process. These coatings are applied on one surface of the glass. The combination of those two coatings provides excellent heat reduction therefore able to improve comfort.*





Sunergy memberikan penampilan yang netral pada bangunan sekaligus memungkinkan banyak cahaya masuk ke dalam bangunan. Hal ini sangat dimungkinkan karena penampilan Sunergy yang netral.

**Karakteristik Umum**

- Kombinasi dua lapisan coating pada kaca Sunergy mampu menolak panas lebih efektif sehingga mengurangi beban listrik untuk AC sekaligus memaksimalkan cahaya masuk sehingga membuat ruangan lebih terang.
- Sunergy menawarkan penampilan yang netral dengan tingkat pantul yang sangat rendah
- Sunergy dapat diproses lanjut menjadi kaca pengaman (heat strengthened, tempered, laminated) maupun sebagai thermal insulation (Insulated Glass Unit)

**Penggunaan**

- Untuk buka-bukaan (jendela) yang diharapkan dapat meningkatkan kenyamanan penghuni dan mengurangi beban listrik
- Untuk semua dinding kaca

**Catatan**

- Hindarkan permukaan kaca dari semburan AC secara langsung dan terus menerus
- Hindarkan persinggungan langsung dengan tirai secara terus menerus dan hindari dari hal-hal yang menimbulkan akumulasi panas, seperti penempatan perabot
- Untuk mendapatkan performa yang maksimal, posisi coating harus dipasang pada posisi dalam (menghadap interior/ posisi 2)
- Gunakan Sunergy tempered dimana kemungkinan terjadi thermal shock atau akumulasi panas sangat tinggi
- Pada waktu pemotongan posisi coating harus berada diatas untuk menghindari goresan akibat partikel-partikel sisa pemotongan yang tertinggal pada meja potong. Hasil potongan kaca harus bersih, tanpa cacat (bergerigi)
- Gunakan rangka yang baik dan memiliki presisi yang tinggi, hati-hati ketika membersihkan sealant dengan thinner, aseton, alkohol, atau yang lainnya, segera bersihkan dengan air bersih
- Bersihkan setiap 2 bulan sekali untuk mendapatkan umur yang panjang dan performa yang maksimal
- Gunakan air biasa atau neutral detergent (non-abrasive detergent) untuk kotoran-kotoran yang sulit, kemudian cuci segera dengan air biasa kembali. Jangan gunakan pembersih yang berupa bubuk.
- Hindarkan dari pembersih yang berupa cairan kimia untuk dinding keramik, batu, dan beton.

*Sunergy gives neutral appearance into building and allows more sunlight transmits inside. This is possible due to neutral appearance of Sunergy.*

**Features**

- *Combination of two layers of coatings makes Sunergy exceptionally able to reduce heat more effectively and maximize natural lighting therefore reduce electricity cost for air conditioner and brighten any rooms*
- *Sunergy offers natural appearance with very low reflective*
- *Sunergy offers flexibility in processing. It can be processed to safety glass (heat strengthened, tempered or laminated) and Insulated Glass Unit*

**Applications**

- *Windows of high grade and high performance buildings. Windows in landed residential, villas to optimize comfort.*
- *For all type of glass walls*

**Notes**

- *Avoid direct & continuously air conditioner air blow facing glass surface*
- *Be careful not to fix a thick curtain or place lockers, furniture, etc closely to the glass in the room; otherwise that may be accumulated heat which will cause crack*
- *To get optimum performance of Sunergy, coating should be installed facing interior (position 2)*
- *Use tempered Sunergy for possible thermal shock and heat accumulation*
- *When cutting the glass, clean cut should be applied as a rule. The coating position should be on top to avoid scratches by the particle left on the cutting table*
- *Use high precision sashes and be careful when removing sealant or grease with thinner, toluene, acetone, alcohol, etc., be sure to rinse with water thoroughly afterwards*
- *Clean the glass at least once every two months for long lasting and maximal performance*
- *Use water for cleaning or a neutral detergent (non-abrasive detergent), then wash it with water. Do not use powder cleaning agent.*
- *Be careful not to allow detergent to adhere to the glass when washing curtain walls, tiles, stone, etc.*

Type Of Glass	Standard Thickness	Standard Size (mm)			
		3210x2134	3210x2250	5100x3210	3210x2440
Sunergy Clear	SNFL	3			✓
		4, 5, 6, 8	✓	✓	✓
		10		✓	✓
Sunergy Green	SNGN	6, 8	✓	✓	✓
Sunergy Blue Green	SNBN	6, 8	✓	✓	✓
Sunergy Euro Grey	SNGE	6, 8	✓	✓	✓



AGC Group

# PLANIBEL G

The Glass with a High Performance Low-E Hard Coating

Planibel G merupakan kaca yang dilapisi dengan 2 pelapis (coating) oksida logam melalui proses CVD (Chemical Vapor Deposition). Pelapis ini dilapiskan hanya pada satu sisi kaca. Adapun 2 pelapis (coating) tersebut adalah Low Emissivity coating, dimana coating tersebut dapat mengurangi panas yang masuk sehingga dapat memberikan kenyamanan lebih bagi orang di dalam ruangnya.

*Planibel G is a glass product that combines application of two layer of emissivity through CVD (Chemical Vapor Deposition) process. These coatings are applied on one surface of the glass. Those two coatings reduces the heat transmittance therefore improve comfort.*



Planibel G memberikan penampilan yang transparan layaknya kaca clear biasa, sehingga memberikan transmisi cahaya yang baik.

### Karakteristik umum

- Emissivitas rendah dari Planibel G tidak hanya menghemat sejumlah besar energi, tetapi juga sangat mudah untuk dilakukan proses lanjut seperti tempered, laminated, dan double glazing unit.
- Lapisan coating pada Planibel G, diterapkan secara online dengan menggunakan suhu tinggi (hampir 600°C) melekat pada permukaan kaca menjadi sangat tahan lama.
- Dengan lapisan coatingnya tersebut, Planibel G menawarkan beberapa fitur, sehingga menjadikan Planibel G kaca Low E yang sangat ideal untuk prosesor.
- Lapisan yang keras dan stabil membuat Planibel G cocok untuk setiap proses. Secara khusus, tidak perlu untuk menghapus lapisan pada tepi untuk perakitan double glazing.
- Planibel G dapat disimpan, dipotong dan dirakit seperti kaca biasa.

### Penggunaan

- Untuk bukaan-bukaan (jendela) yang diharapkan dapat meningkatkan kenyamanan penghuni dan mengurangi beban listrik.
- Untuk semua tipe dinding kaca.

### Catatan

- Planibel G mengurangi transmisi energi; dikombinasikan dengan Stopsol, Sunergy atau kaca sejenisnya, juga dapat memberikan kontrol panas matahari yang baik.
- Untuk meningkatkan kinerja insulasi termal Planibel G dapat dirakit menjadi double glazing unit. Double glazing unit juga dapat memberikan insulasi akustik tergantung pada komposisi yang digunakan.
- Selain itu dalam rangka untuk mematuhi peraturan penggunaan kaca pengaman dalam industri konstruksi, Planibel G dapat dirangkai dalam unit kaca laminasi terintegrasi ke dalam double glazing unit.
- Hindarkan permukaan kaca dari semburan AC secara langsung dan terus menerus.
- Hindarkan persinggungan langsung dengan tirai secara terus menerus dan hindari dari hal-hal yang dapat menimbulkan panas, seperti penempatan perabot
- Untuk mendapatkan performa yang maksimal, posisi coating harus dipasang pada posisi 2.
- Gunakan Planibel G tempered dimana kemungkinan terjadi thermal shock atau akumulasi panas sangat tinggi.
- Pada waktu pemotongan posisi coating harus berada di atas untuk menghindari goresan akibat partikel-partikel sisa pemotongan yang tertinggal di meja potong. Hasil potongan kaca harus bersih, tanpa cacat (bergerigi)

*Planibel G gives appearance as transparent as Clear Glass does, therefore allows excellent sunlight transmits.*

### Features

- *Low emissivity Planibel G not only saves a considerable amount of energy, but it also the easiest Low E-coated glass to process.*
- *The coating, applied online using a high temperature (almost 600°C) adheres to surface of the glass becoming remarkably durable.*
- *With its super-hard coating Planibel G boasts several features, making it the deal low emissivity glass for processors.*
- *Its hard and stable coating makes Planibel G suitable for any processing operation. In particular, it is not necessary to erase the coating on the edges for assembly in double glazing.*
- *Planibel G may be stored, cut, and assembled like ordinary glass, provided the normal precautions for hard coated glass are followed.*

### Applications

- *Windows of high grade and high performance buildings.*
- *For all type of glass walls.*

### Notes

- *Planibel G prevents energy loss; combined with Stopsol, Sunergy or similar type of glass, it can also provide solar control.*
- *To improve its thermal insulation performance Planibel G is assembled in double glazing units. Double glazing can also provide acoustic insulation depending on composition used.*
- *Moreover in order to comply with legislation increasingly requiring the use of safety glass in the construction industry Planibel G may be assembled in laminated glass unit integrated into double glazing unit.*
- *Avoid direct & continuously air conditioner air blow facing glass surface*
- *Be careful not to fix a thick curtain or place lockers, furniture, etc closely to the glass in the room; otherwise that may be accumulated heat which will cause crack.*
- *To get optimum performance of Planibel G, coating should be installed facing interior (position 2)*
- *Use tempered Planibel G for possible thermal shock and heat accumulation.*
- *When cutting the glass, clean cut should be applied as rule. The coating positions should be on top avoid scratches by the particle left on the cutting table.*

Type Of Glass	STANDARD THICKNESS (mm)	STANDARD SIZE (mm)		
		3210 x 2440mm	3210 x 2550mm	5100 x 3210mm
Planibel G	PNGFL	3.2	✓	✓
		4	✓	✓
		5	✓	✓
		6	✓	✓



AGC Group

# INDOFIGUR

Patterned Glass

Indofigur diproduksi dengan cara yang disebut roll-out process, dimana leburan bahan baku kaca dialirkan melalui sepasang rol dengan satu rol memiliki pola tertentu, sehingga pada salah satu permukaan kaca akan tercetak pola sesuai dengan pola pada rol.

*Indofigur is produced by the most advanced roll-out process. The melting blend of glass materials is flown through a pair of rollers where one of the rollers has a pattern that will printed on the glass surface.*

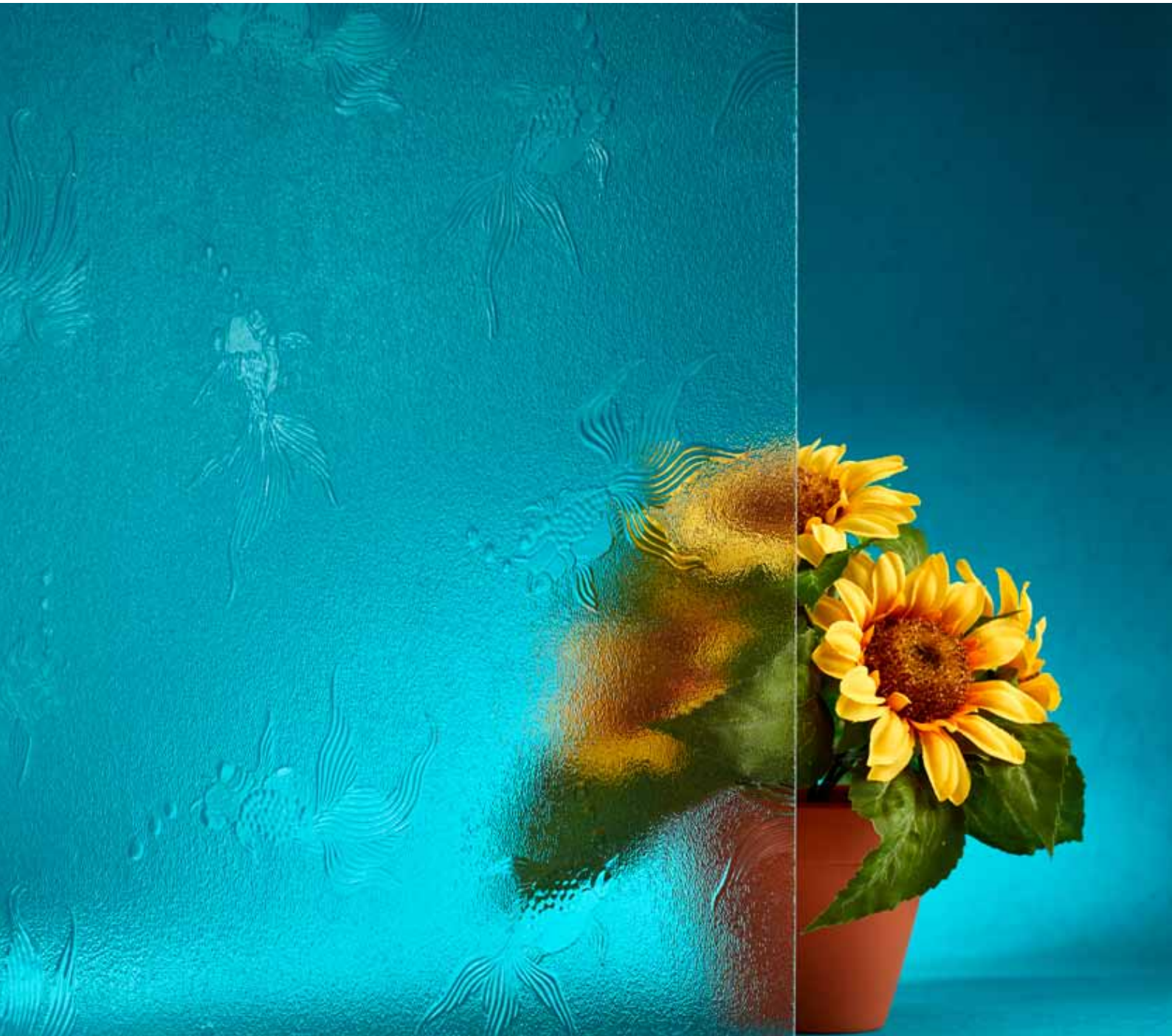



### Karakteristik Umum

- Indofigur dengan polanya yang atraktif dan daya tembus yang terbatas akan memberikan efek dekoratif yang sangat menarik.
- Berkas cahaya yang melalui indofigur akan dibiaskan dengan tingkat pembiasan dan tingkat pembayangan (daya tembus) yang bervariasi. Hal ini memberikan efek pencahayaan dan efek pembayangan yang menakjubkan.
- Khusus indofigur non glare, memiliki kemampuan untuk mereduksi silau secara maksimum.

### Penggunaan

- Untuk partisi, dinding, pintu, perabotan rumah, lampu dan lain-lain pada rumah tinggal, kantor, hotel, pertokoan, rumah makan dan bangunan-bangunan komersial dan industrial lainnya yang membutuhkan unsur dekoratif.
- Untuk ruang-ruang dimana cahaya masih diperlukan tapi daya tembus pandang tidak diharapkan, seperti pada ruang kamar mandi.
- Khusus untuk indofigur non glare digunakan untuk bingkai foto/gambar, sehingga dilihat dari sudut pandang manapun gambar tetap jernih tanpa adanya efek silau.

### Features

- *Indofigur with its attractive patterns and limited visibility will add to decorative effects and beauty.*
- *Light going through Indofigur will be transmitted at various degrees of diffused light and creates many different atmospheres of light and shade.*
- *Specially for non glare Indofigur it can reduce glare completely*

### Applications

- *Window partitions, screens, doors, furniture, fluorescent fixtures of residence, offices, hotels, shops, restaurants, and all other commercial and industrial buildings where decorations is desirable.*
- *Places where its necessary to let light through but obstruct the line of sight, e.g. bathrooms.*
- *For picture framing, enabling the picture to be seen without reflection from any angle.*

Jenis dan Spesifikasi

Type and Specifications

PRODUCT NAME	TYPES		STANDARD THICKNESS (mm)				STANDARD MANUFACTURING SIZE (Inch)				WEIGHT (kg/m <sup>2</sup> )
			2	3	4	5	44 x 36	60 x 48	72x48	84 x 48	
INDOFIGUR Pattern Glass	Mislite	FM		✓		✓	5	3,5	3,5	5	2 mm = 5
	Flora	FF		✓				3			3 mm = 7
	Non Reflective	NR	✓					2	2		4 mm = 10
	Goldfish	GF		✓				3			5 mm = 12



# ASAHIMAS MIRROR

New Generation Mirror

Asahimas telah berhasil menerapkan teknologi mutakhir dari AGC Europe dalam memproduksi kaca cermin Asahimas untuk memenuhi tuntutan akan kualitas produk yang terus meningkat.

*Asahimas has achieved in producing New Generation mirror with adopted technology from AGC Europe.*



Cermin Asahimas sangat berbeda dengan kaca cermin standar yang ada saat ini.

- Berbeda karena lapisan metaliknya tidak menggunakan tembaga
- Berbeda karena kualitas produk ini jauh di atas standar kualitas cermin yang ada saat ini
- Berbeda karena produk ini lebih tahan terhadap bahan-bahan kimia pembersih kaca yang agresif
- Berbeda karena kejernihan pantulan yang dihasilkan tanpa distorsi sedikitpun. Cermin Asahimas sangat ramah terhadap lingkungan, dimana teknologi produksinya dapat mengurangi kadar ammonia hingga 90% pada proses silvering line.

### Tidak Terjadi Cacat Cloud

Cermin biasa memiliki suatu lapisan tembaga yang dapat teroksidasi oleh reaksi-reaksi kimia yang menembus lapisan cat (khususnya bahan polimer yang terdapat dalam adhesive yang digunakan dalam pemasangan kaca cermin). Ketika lapisan tembaga telah teroksidasi secara sempurna, oksida tembaga (yang berwarna agak coklat) akan terdifusi melalui lapisan perak dan mencapai permukaan antara lapisan perak dan kaca yang akan menimbulkan noda berwarna kecoklat-coklatan (brownish) cacat ini disebut cloud. Pada cermin Asahimas cacat cloud tidak akan terjadi.

### Penggunaan

- Untuk dekorasi interior pada bangunan-bangunan umum
- Perkantoran
- Rumah tinggal
- Pelapis dinding
- Kolom
- Langit-langit
- Perabotan dan lain-lain

### Kelebihan-Kelebihan Cermin Asahimas

- Cermin yang diproduksi dengan teknologi paling canggih saat ini, dan dibawah pengawasan standar mutu AGC Europe.
- Memiliki daya tahan lebih terhadap pengaruh cuaca, kelembaban, korosi dan bahan-bahan kimia agresif, seperti ammonia, acetic, acid, yang terkandung dalam beberapa produk-produk perawatan/pembersih
- Lebih tahan terhadap berbagai jenis bahan perekat yang umum digunakan untuk memudahkan pemasangan.

*Asahimas Mirror is completely different from ordinary mirror.*

- *Different because no copper substance in its metallic coatings.*
- *Different because its qualities exceed current manufacturing standards.*
- *Different because it stands against aggressive chemicals contained in maintenance products.*
- *Different because its reflection is perfectly clear and without distortion. Asahimas Mirror is also environmentally friendly. It's ecological reduces the ammonia content of the silvering line's waste by 90%*

### No Clouding

*Standard mirrors have a layer of copper. Polymerisation agents in the adhesives used to install the mirrors in place, can cause reactions with the copper resulting in oxidization. When the copper oxidizes completely, the copper oxide (which is brownish in color) permeates through the silver coating and reaches the boundary where the glass and silver meets, resulting in brownish stains. In Asahimas mirror, it is cloud proof.*

### Applications

- *For interior decoration of public buildings shopping malls*
- *Residential housing*
- *As wall coverings*
- *Ceiling*
- *Furniture etc.*

### The Advantages of New Generation Mirror

- *Asahimas Mirror is produced with the latest technology available today under supervision from AGC Europe.*
- *Has higher resistance against climate, humidity, corrosion and aggressive chemicals such as ammonia, acetic acid which are contained in some of the maintenance products.*
- *Compatible with various types of adhesives for mounting purposes.*

Jenis dan Spesifikasi

Type and Specifications

PRODUCT NAME THICKNESS (mm)	TYPES		STANDARD				STANDARD MANUFACTURING SIZE (Inch)								WEIGHT (kg/m <sup>2</sup> )		
			2	3	4	5	6	48x34	48x40	60x40	60x48	72x48	96x72	120x84		126x84	144x84
MIRALUX	Miralux	MX				✓					5	5	5	5			
DANTALUX	Dantalux	MT	✓	✓		✓	✓	2	3	3	3	3	5,6	5,6			
DIAMOND CLEAR MIRROR DECOMIRROR	Diamond Clear Mirror	MTJ				✓									5		
	Decomirror Black	DMDG				✓							5	5			
	Decomirror Bronze	DMBR				✓	✓						5	5			3mm=7
	Decomirror Grey	DMGE				✓	✓						5		5	6	5mm=12
SAFETY BACK	Safety Back	MTSBW			✓	✓	✓						5,6	5,6			6mm=15

Glazing For Interior

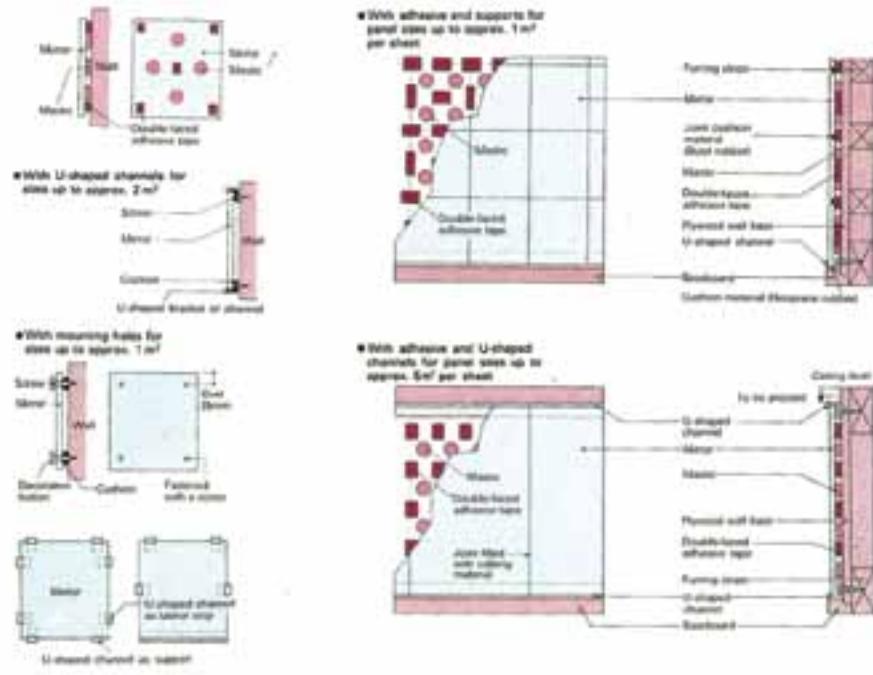

Danta Prima Mirror

New Generation Mirror

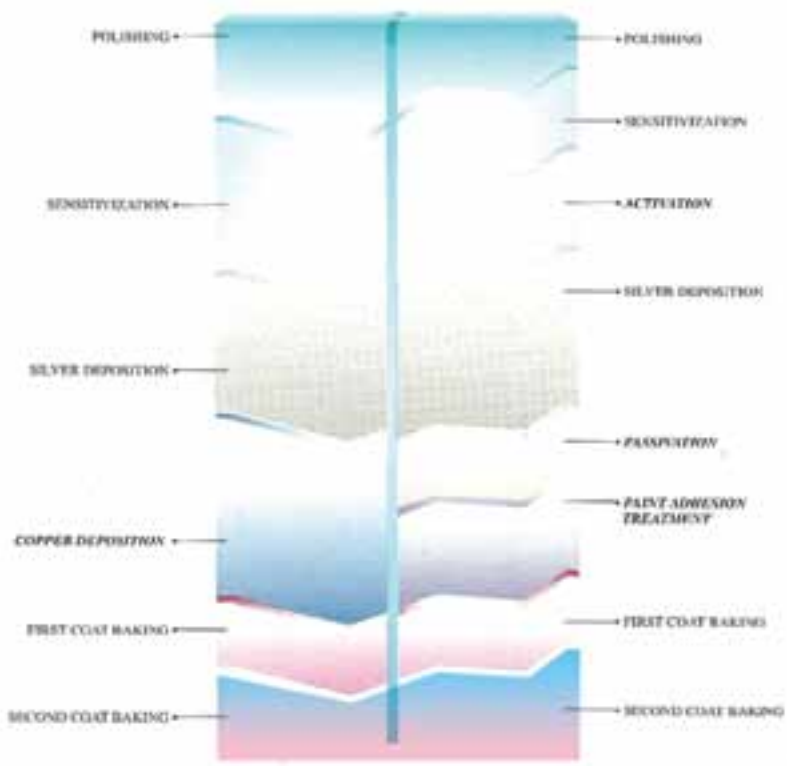



## **Miralux**

Miralux adalah salah satu cermin yang luar biasa yang dihasilkan oleh Asahimas dan dinamakan sebagai generasi baru tahan korosi dan cermin ekologis. Dengan kata lain, diproduksi dengan tidak mengandung tembaga dan timbal, dan pada proses silveringnya menggunakan metode yang dapat mengurangi jumlah amonia. Miralux memberikan refleksi yang sempurna dan bebas dari distorsi karena diproduksi dengan material kaca kualitas tinggi. Sebagai pelopor dalam industri kaca di Indonesia, Asahimas telah didukung oleh AGC Europe, sebuah perusahaan cermin yang sangat diakui dan terbesar di dunia, untuk menghasilkan Miralux. Melalui teknologi revolusioner di Eropa, Miralux telah melalui kontrol kualitas yang kompetitif. Oleh karena itu, Miralux dikembangkan sebagai cermin anti korosi, anti noda hitam di mana produk lain yang sejenis mungkin tidak memiliki keunggulan tersebut. Keuntungan lain dari Miralux adalah untuk menghasilkan kesan ruang yang luas serta lingkungan cerah.

## **Dantalux**

Cermin generasi baru Dantalux adalah bagian dari produk cermin Asahimas (cermin yang tidak mengandung tembaga dan tahan korosi) yang dikembangkan dan dipatenkan oleh AGC Europe. Perbandingan hasil pengujian cermin dicelupkan ke dalam larutan asam klorida 0.5N jelas cermin Dantalux Asahimas menunjukkan fitur lebih tahan korosi. Cermin Asahimas Dantalux, yang lebih tahan korosi, pasti akan memberikan nilai lebih untuk biaya yang dikeluarkan.

## **Dantalux Safety Back**

Dantalux Asahimas juga tersedia dalam versi safety back di mana polypropylene film bening atau putih diaplikasikan pada bagian belakang cermin untuk keselamatan tambahan. Polypropylene film juga memberikan lapisan tambahan perlindungan terhadap kelembaban dan serangan kimia. Dantalux Safety Back memenuhi standard AS/NZS 2208 - Grade A safety glazing material. Salah satu standard safety glazing paling ketat di dunia.

## **Decomirror**

Asahimas memperkenalkan Anda Decomirror, cermin yang unik untuk gaya hidup modern Anda. Decomirror diproduksi dengan menerapkan lapisan perak ke berbagai kaca berwarna kualitas tinggi Asahimas. Decomirror tidak memiliki distorsi dan permukaannya benar-benar datar. Keahlian Asahimas yang terkenal dalam membuat kaca tercermin dalam produk Decomirror. Desain interior menggunakan cermin kembali menjadi trend. Apakah Anda ingin menyingkirkan pandangan tidak indah, membuat ruangan yang penuh sesak terasa lebih luas, atau menjadi lebih hemat energi, cermin dapat membantu untuk meringankan masalah. Desainer dan dekorasi rumah melihat nilai dari cermin di semua ruangan di mana ruang dan cahaya berperan dalam meningkatkan suasana. Gaya hidup di daerah perkotaan menuntut kualitas tinggi dan cermin unik untuk mencerminkan gaya hidup energik mereka. Dan cermin biasa bukanlah jawaban, mereka menuntut lebih dari itu. Mereka ingin sesuatu yang berbeda.

## **Miralux**

*Miralux is one of the outstanding mirrors produced by Asahimas and named as the new generation corrosion resistant and ecological mirror. In other words, it is completely clear from copper and lead through the process of silvering line, a way to reduce the amount of ammonia. Miralux will perform a perfect reflection and free from distortion since it is magnificent designed by the high quality floated glass. As the pioneer in glass industry in Indonesia, Asahimas has been supported by AGC Europe, a highly recognized and largest mirror company in the world, to produce Miralux. Through the revolutionary technology in Europe, Miralux has been approved by the competitive quality control. Therefore, Miralux is established as a free corrosion, free black spot or free cloud mirror where other products in the line may lack of. Another advantage of Miralux is to generate an impression of a spacious room as well as brighter environment.*

## **Dantalux**

*Dantalux new generation mirrors is part of the family of Asahimas mirrors (copper free & corrosion resistance mirrors) developed & patented by AGC Europe. Comparative test result of mirrors dipped into 0.5N hydrochloric acid solution clearly shows the more corrosion resistant feature of Dantalux Asahimas Mirrors. Dantalux Asahimas Mirrors, being more corrosion resistant, would definitely give more value for money.*

## **Dantalux Safety Back**

*Dantalux Asahimas is also available in the safety back version in which a translucent or white polypropylene film was applied to the back of the mirrors for additional impact safety. The safety film also provides an additional layer of protection against humidity and chemical attacks. Dantalux Safety Back complies with AS/NZS 2208 - Grade A safety glazing material. One of the strictest standard in the world for safety glazing.*

## **Decomirror**

*Asahimas introduces you Decomirror, a unique mirror for your modern lifestyle. Decomirror is produced by applying silver coating to various Asahimas high quality tinted glass. It has no distortion and its surface is absolutely flat. Asahimas renowned expertise in glass making is reflected in this magnificent product. Designing with mirrors is making a comeback. Whether you want to get rid of an ugly view, make a crowded room feel spacious, or become more energy efficient, mirrors can help to alleviate the problems. Designers and home decorations see the value of mirror in all rooms where space and light play a part in enhancing the ambiance. Vibrant lifestyle in urban area demands high quality and unique mirror to reflect their energetic lifestyle. And ordinary mirror is not the answer. They demand more than that. They want something different.*



# LACOBEL

Varnished Glass

Dengan kombinasi keahlian dan teknologi tinggi, Asahimas mempersembahkan inovasi terkini yaitu Lacobel, kaca cat pertama di Indonesia yang diproduksi secara massal. Melalui proses produksi yang dikembangkan oleh Asahimas menjamin konsistensi dan homogenitas cat pada setiap lembar Lacobel.

*Combining its expertise and cutting edge technology, Asahimas innovatively presents Lacobel, the first mass produced painted glass in Indonesia. Through production process Asahimas has developed, ensures the consistency and homogeneity of each Lacobel sheet.*



## Karakteristik umum

- Lacobel adalah kaca yang dicat pada salah satu sisinya
- Cat tersebut diaplikasikan pada kaca-kaca Clear dan Diamond Clear (Low Iron Glass)
- Lacobel memenuhi tuntutan yang ditetapkan oleh saat ini tren desain interior architectural dan mudah dikombinasikan dengan bahan lain seperti kayu, baja atau batu.
- Lacobel tersedia dalam 7 warna standard (Pure White, Soft White, Luminous Green, Classic Black, Classic Red, Luminous Red dan Classic Orange) dan 7 warna non-standar (Yellow Rich, Rich Aluminium, Metal Grey, Luminous Blue, Pearl White, Light Beige dan Starlight Black)

## Penggunaan

- Berbagai macam pemakaian untuk interior seperti: partisi ruangan, tutup dinding, dll
- Furniture : lemari, meja, kitchen set, dan lain-lain

## Catatan

- Untuk pemasangan, gunakan sealant yang tidak mengandung asam. Jangan menggunakan sealant yang mengandung asam, karet dan lem berbasis polyurethane
- Aplikasikan sealant tegak lurus untuk menjamin sirkulasi udara antara sisi belakang Lacobel dengan material dibelakangnya.
- Gunakan air dan kain untuk membersihkan kotoran pada Lacobel
- Sisi dilapisi kaca Lacobel harus selalu ditempatkan terhadap struktur pendukung sehingga dilindungi dari kerusakan dan agar warna dan tampilan kaca dilindungi.

## LACOBEL SAFE – keamanan ekstra

Lacobel juga hadir dalam versi khusus: sebuah film polypropylene yang disebut "SAFE" diterapkan ke sisi bercoating.

Film polypropylene ini memiliki fungsi ganda :

1. Jika pecah kaca, pecahan-pecahan akan menempel pada film dan akan menghindari cedera atau kerusakan lebih lanjut.
2. Permukaan kaca yang bercoating terlindungi dari goresan

## Features Lacobel

- *Lacobel is a glass with paint applied on one side*
- *Those high quality are applied on various Asahimas Indoflot and Diamond Clear (Low Iron Glass)*
- *Lacobel Glass meets the demands set by current interior architectural design trends is easily combined with other material such as wood, steel, or stone.*
- *Lacobel is available in 7 standard colours (Pure White, Soft White, Luminous Green, Classic Black, Classic Red, Luminous Red dan Classic Orange) and 7 non standard colours (Yellow Rich, Rich Aluminium, Metal Grey, Luminous Blue, Pearl White, Light Beige dan Starlight Black)*

## Applications

- *Various interior usage, such as: room partition, wall cover, etc*
- *Furniture : wardrobe door, table, kitchen set, etc.*

## Notes

- *Use non acid based silicones for installation. Usage of acid content silicones, rubber and polyurethane based glues are prohibited*
- *Apply silicones in vertical stripes to ensure the excellent flow of air between the back of the Lacobel and the surface to which it is being glued*
- *Use water and soft fabric to clean Lacobel*
- *The coated side of Lacobel glass should always be place against the supporting structure so that it is protected from damage and so that the colour and appearance of the glass are protected.*

## LACOBEL SAFE – extra safety

Lacobel glass also comes in a special safety version : A polypropylene film called "SAFE" is applied to the coated side of the glass.

This film serves a double purpose :

1. *If the glass breaks, the shards will stick to the film avoiding injury or any further damage*
2. *The coated surface of the glass is protected from scratches.*



# TEMPERED GLASS

High Strengthened Glass Which is Highly Safe Even if Broken

Kaca Tempered merupakan kaca yang diperkeras dengan cara memanaskan kaca float biasa hingga mencapai temperatur sekitar 700°C dan kemudian didinginkan mendadak dengan menyemburkan udara secara merata pada dua permukaan kaca. Dari proses ini maka terjadi perubahan fisik kaca yaitu terjadi perubahan gaya tekan dan gaya tarik pada kaca, tapi secara visual tidak terjadi perubahan.

*Tempered Glass is heat-treated strengthened glass, by heating ordinary float glass to the softening point (up to 700°C) and then quenching it by a uniform blast of air evenly to both surfaces. The glass undergoes a physical change, in its structure without affecting its visual appearances.*



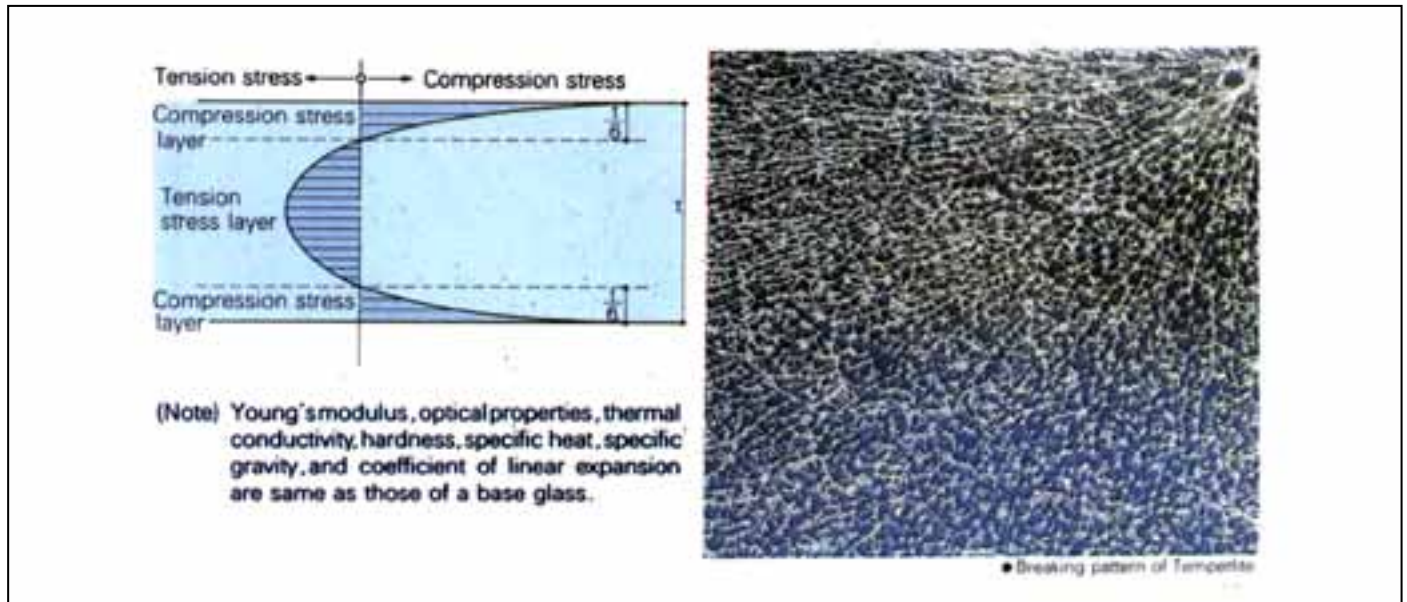

### Karakteristik Umum

- Dengan ketebalan yang sama, kekuatan kaca tempered mampu mencapai 3 s/d 5 kali lipat dari kekuatan kaca biasa terhadap beban angin, tekanan air, benturan dan sebagainya.
- Terhadap perubahan temperatur yang tinggi dan cepat (thermal shock) maka kaca Tempered memiliki kemampuan 3 kali lebih besar dari kemampuan kaca float biasa.
- Jika pecah, pecahan kaca tempered berbentuk kecil-kecil dan tumpul, sehingga sangat aman bagi manusia (tidak akan melukai manusia).

### Penggunaan

- Pintu-pintu bebas rangka
- Bukaan-bukaan/dinding kaca pada bangunan yang menuntut tingkat keamanan tinggi
- Dinding kaca batas tangga, escalator dan lift.
- Furniture dan dekorasi, seperti meja kaca, lemari pajang dan lain-lain
- Kaca-kaca jendela kendaraan bermotor
- Penggunaan-penggunaan lain yang memerlukan kekuatan kaca khusus, seperti untuk dinding lapangan squash dan lain-lain.

### Catatan

- Karena kaca tempered memiliki keseimbangan yang baik sekali antara tegangan tekan dengan tegangan tariknya, maka kaca tempered tidak boleh diganggu oleh proses-proses lebih lanjut yang dapat membahayakan keseimbangan tersebut, seperti pemotongan, penggosokan tepi, pembuatan lubang dan lain-lain. Semua ukuran dan jenis aksesoris harus sudah dapat ditentukan dengan pasti sebelum kaca Tempered diproses.

### Features

- On the same thickness tempered glass has bending and impact strength which is 3 to 5 times higher than that of ordinary glasses.
- As resistant to rapid temperature changes (thermal shocks). Tempered glass is approximately 3 times as ordinary float glasses.
- When broke, tempered glass breaks into fine particles, to prevent serious injuries.

### Applications

- Frameless tempered glass doors
- Openings that require high safety levels
- Staircase handrails, escalators side plates, elevators panels.
- Furniture and decorations such as glass table, show case, etc.
- Vehicle windows, side panels.
- Special uses such as squash court wall partitions.

### Notes

- As well balanced in tension and compression stress, it can not be cut, sanded or belt. All dimensions and specifications must be determined precisely before tempering process.

- Kaca tempered sulit sekali retak oleh benturan ringan, tetapi akan pecah oleh goresan yg dalam. Dalam hal ini kaca tempered glass tidak langsung pecah, tetapi lambat laun pasti akan pecah.
- Hati-hati kerusakan serius pada tepi atau permukaan kaca, karena akan menjadi sumber kepecahan.
- Jika kaca tempered mengalami benturan hingga menghasilkan titik kepecahan, maka titik kepecahan ini akan bergerak keseluruh permukaan kaca dan memecahkan kaca tersebut. Dalam hal ini maka kaca tempered tidak langsung runtuh dengan tiba-tiba.

- *Tempered glass is not cracked or weakened if it is slightly damaged, but may be broken if deep scratches are made with a hard material, in such a case, the glass may not break immediately, but may break after sometime has passed.*
- *Tempered glass is not unbreakable. Be careful not to damage edges or surface heavily; otherwise the glass may break.*
- *When hit, the breaking force is distributes throughout the whole surface, breaking into small, similar blunt pieces, but will not fall immediately.*



# LAMINATED SAFETY GLASS

Shatter Proof Break Resistant Glass



Laminated Safety Glass merupakan kaca dengan tingkat keamanan dan perlindungan yang tinggi terhadap penghuni. Jika terjadi sesuatu yang menyebabkan pecahnya kaca, maka kaca lamisafe ini tidak akan berhamburan, tapi hanya retak dan sangat sulit ditembus.

*Laminated Safety Glass is an extra-safe glass and shatterproof that provides ultimate protection. When broken it will not spread and blow apart, but it will only crack and it can't be penetrated.*



Laminated Safety Glass terdiri dari komposisi satu atau lebih lembaran film polifinil yang transparan, fleksibel dan sangat kuat dengan satu atau lebih lembaran kaca float dan disatukan melalui proses pemanasan dan pengepresan. Polifinil yang digunakan sangat jernih, bebas distorsi, tidak berkerut, dan tidak akan mengurangi sifat transparansi kaca. Laminated Safety Glass juga tahan terhadap kelembaban dan panas. Dengan demikian, Laminated glass merupakan material yang sangat tepat untuk bahan transparan yang aman.

**Karakteristik Umum**

- Pecahan Laminated Safety Glass tidak akan jatuh atau berhamburan, namun tetap melekat pada filmnya, dan kaca tetap terpasang pada rangkanya.
- Laminated Safety Glass yang sudah pecah, akan sulit sekali ditembus oleh manusia, sehingga memberikan tingkat keamanan yang sangat tinggi bagi penghuninya (anti maling).
- Dengan berbagai kombinasi antara jenis dan warna kaca dengan warna film polifinil, maka dapat diperoleh berbagai jenis dan warna Laminated Safety Glass yang sangat dapat bervariasi.

**Penggunaan**

- Untuk atap kaca, sky lights dan lain-lain, dimana tidak diinginkan adanya reruntuhan kaca jika pecah.
- Untuk lemari pajang barang-barang berharga (anti maling).
- Untuk penggunaan khusus seperti untuk kendaraan bermotor (mobil, kereta api, kapal laut dan pesawat udara) tangki air, aquarium berukuran besar, kaca tahan peluru dan lain-lain.

*Laminated Safety Glass contains one or more sheets of flexible, tough and transparent polyvinyl film laminated between two or more sheets of flat glass through a heating and pressing process. The polyvinyl film used in Laminated Safety Glass is perfectly clear and free of any discoloration. Laminated Safety Glass is also highly resistant to moisture and heat. The polyvinyl film will not blister or in any way detract from the perfect clarity of the glass sheets. All this outstanding features make Laminated Safety Glass the perfect material whenever safety glass or a safety glazing material is needed.*

**Features**

- *Laminated Safety Glass doesn't allow broken pieces to shatter or drop of it it should be broken but will remain firmly attached to its interlayer film and the glass will remain it's frame.*
- *The broken Laminated Safety Glass will be difficult to penetrate. This acts as a deterrent to robbers and thieves, and protects lives and property.*
- *Various kind and colours of Laminated Safety Glass are available by combining various types of flat glass and interlayer film colours, for variety of uses.*

**Applications**

- *For roofing, skylights, etc where no sharp glass pieces are desired.*
- *For anti thief show cases.*
- *For special usage as car windows, air craft windshields, large aquarium, bullet proof glass, etc.*

Laminated Safety Glass Diagram

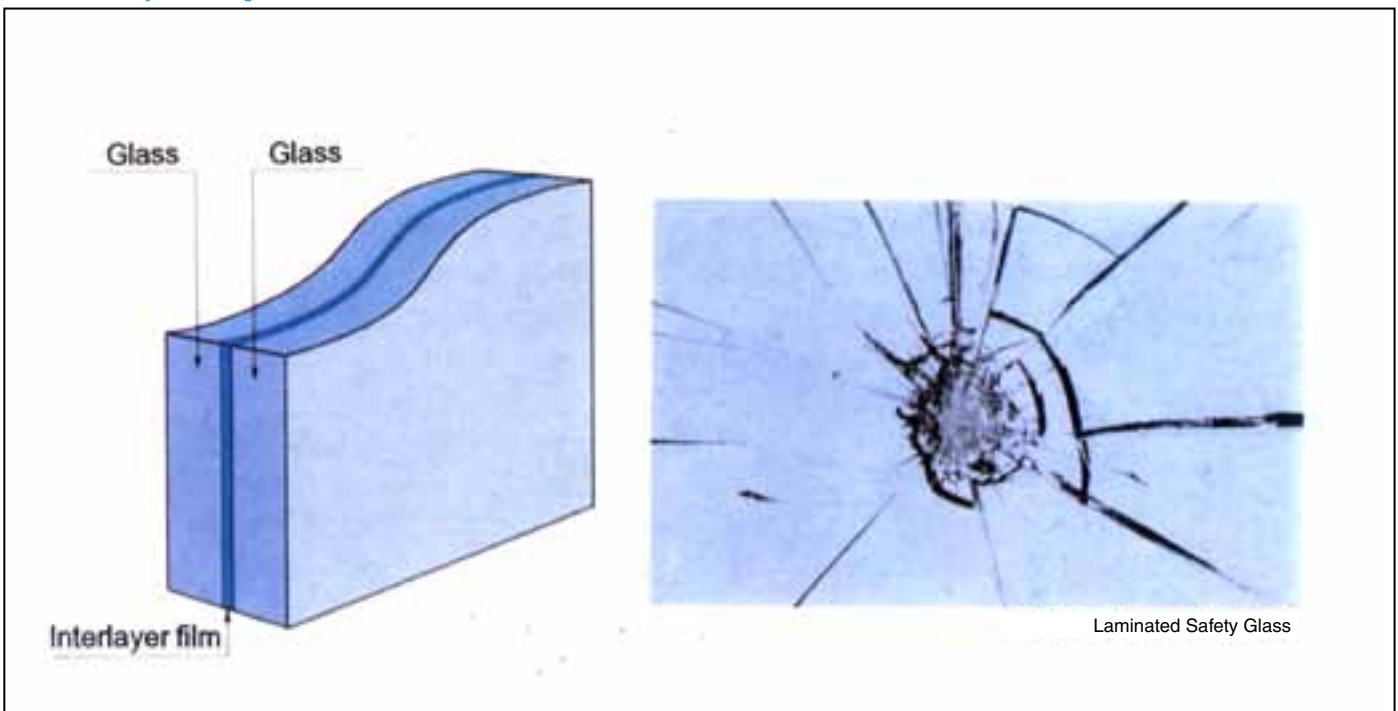





### Catatan

- Hindari proses lanjut pada Laminated Safety Glass seperti pemotongan, pembuatan lubang dan aksesoris lain, karena walaupun mungkin bisa dikerjakan tapi akan sangat sulit dan tidak rapi. Semua ukuran dan aksesoris harus sudah tepat sebelum proses dikerjakan.
- Hindarkan penempatan kaca pada temperatur 70° C dalam waktu yang lama, karena dapat menimbulkan kerusakan pada filmnya yang merupakan bahan organik.
- Hindari untuk mengekspos sisi tepi dari Laminated Safety Glass sehingga langsung berhubungan dengan udara luar, karena melalui sisi tepi yang tidak terlindungi tersebut terjadi kondensasi dan delaminasi.
- Hindari larutan-larutan organik langsung berhubungan dengan sisi tepi dari laminated safety glass dan gunakan sealant yang netral (tidak bersifat asam atau basa).
- Untuk berbagai penggunaan, komposisi Laminated Safety Glass dapat ditentukan berdasarkan jumlah lebar film dan jumlah lebar kaca yang digunakan, tebal film dan tebal kaca serta berbagai kombinasi jenis, warna kaca dan warna film.
- Laminated Safety Glass terdiri lebih dari dua lembar kaca, biasanya digunakan untuk bangunan-bangunan, sedangkan yang terdiri dari dua lembar biasanya untuk penggunaan-penggunaan khusus seperti kaca anti peluru, kaca aquarium yang besar dan kaca pesawat terbang.

### Notes

- *All dimensions and characteristic must be ordered prior to processing, as a bad finish will result through manipulation cutting, etc.*
- *Avoid placing the glass to temperatures in excess of 70° C for long periods of time. This can cause damage to the film which is an organic material.*
- *Be careful not to expose the edge of Laminated Safety Glass directly to the open air, when it using outdoors ; otherwise, the edge may absorb moisture and cause peeling.*
- *Be careful not to apply an organic solvent to the edge because it damages the butyral film.*
- *Laminated Safety Glass composition can be determined y the amount of film and glass layer used, the thickness of its film and glass and also combination of colours and film, etc.*
- *Two layers of Laminated Safety Glass are usually required for buildings and multilayered Laminated Safety Glass is usually used for bullet proof glass, large aquarium, plane windshield, etc.*

Ketebalan Film	Penggunaan
15 mil (0,375 mm) 30 mil (0,75 mm) 60 mil (1,50 mm)	Mencegah kejatuhan dan keruntuhan kaca dimana daya tembus tidak diinginkan untuk mencegah tindak kejahatan.

Film Thickness	Application
15 mil (0,375 mm) 30 mil (0,75 mm) 60 mil (1,50 mm)	To prevent dropping and shattering where penetration resistance is required crime prevention.

### Jenis dan Spesifikasi

### Type and Specifications

PRODUCT NAME	THICKNESS (mm)	WEIGHT (kg/m <sup>2</sup> )	WIND PRESSURE RESISTANCE *2) STRENGTH (kg)	
			LAMINATED GLASS	INDOFLOT
Laminated Safety Glass	3+3	15	250	440
	4+4	20	325	800
	5+5	25	540	1000
	6+6	30	720	1200
	8+8	40	1150	1700

\*1 Untuk komposisi lain, silahkan hubungi dan konsultasikan dengan PT Asahimas Flat Glass, Tbk.

\*2 Beban berat (kg) = Beban tekanan angin (kg/m<sup>2</sup>) x luas kaca (m<sup>2</sup>)

\*1 For other composition required please contact and consult to PT Asahimas Flat Glass, Tbk

\*2 Allowable load (kg) = allowable wind pressure (kg/m<sup>2</sup>) x area of glass (m<sup>2</sup>)



AGC Group

# CURVED GLASS

Add Elegance To Building Exteriors

Sejalan dengan perkembangan desain arsitektur bangunan yang mengarah kepada bentuk-bentuk kontemporer, seperti bentuk-bentuk lengkung, maka kaca pun dituntut untuk bisa memenuhi tuntutan tersebut.

*As the growing complexity of contemporary design, e.g. variety of curved shapes, it has also led to increase demand for different shapes of glass.*



Penggunaan kaca lengkung untuk bangunan meliputi ruang dalam maupun ruang luar seperti bentuk muka bangunan, sudut bangunan/jendela sudut, skylights, lemari pajang, perabotan dan dekorasi ruang dalam. Kaca lengkung dibentuk dengan menggunakan kaca lembaran yang dipanaskan kembali sehingga mencapai fase lunak, kemudian dicetak dengan cetakan tertentu sesuai dengan bentuk yang diinginkan. Proses kaca lengkung ini tergantung pada ketebalan kaca, bentuk, ukuran dan lengkungannya. Untuk ini konsultasikan terlebih dahulu dengan kami.

**Catatan**

Pastikan bahwa rangka atas dan rangka bawah benar-benar dalam posisi yang sejajar. Sebaiknya gunakan ukuran yang sesuai dengan ukuran keadaan lapangan, bila perlu buatlah guide line dari kayu. Gunakanlah tiga buah setting blocks pada bagian bawah kaca yaitu pada bagian tengah dan bagian tepi kanan-kiri berjarak 1/6 bagian panjang kaca dari tepi.

Varieties of curved glass are extensively used on both interior and exterior of building facades, corner windows, skylights, display windows and interior décor.

The basic technology used for Curved Glass is to soften it under high temperature and shape it along a mold. Glass curving process limit is dependent on the glass thickness, shaped dimensions, and curvature. Thus, please contact us for further specification.

**Note**

Always carefully check that the upper and lower frames are vertically positioned. It is better to use actual-size drawings, when ordering curved glass and frames, if necessary make the wooden guide line. In order to obtain precise shape, use three setting blocks at the lower side of the glass, on the center and on two points 1/6 of its length from each glass corner.

Limitations on Shapes and Sizes

Process	Shallow Curving	1/4 curving	> 1/4 curving
Shape	 $\theta < 90^\circ$	 $\theta = 90^\circ$	 $\theta > 90^\circ$
Radius = R (mm)		R min = 250 mm R max = --  The radius shall be measured from the inside face of the glass as shown in the figure above	
Maximum size (mm)	W x H x D = 2500 x 4000 x 700 or W x H x D = 4000 x 2500 x 700		

**Spesifikasi yang Diperlukan untuk Order**

1. Jenis kaca dan ketebalannya
2. Bentuk
3. Ukuran (Tinggi, lebar, radius, dan informasi lain termasuk metode pengukurannya)
4. Gosokan tepi kaca yang diinginkan
5. Pemasangan yang diizinkan
6. Penggunaan

**Necessary Specification for Order Placement**

1. Glass kind and thickness
2. Shapes (S)
3. Dimensions (Height, width, radius, and other related information including a clear description of the measuring methods)
4. Description of the edge polishing requirements
5. Clearance allowance of glazing
6. Application



# CURTAIN WALL

## Non Structural Glass Walls

Curtain wall merupakan dinding non-struktur yang banyak digunakan pada konstruksi dinding muka bangunan tinggi. Curtain wall juga sering disebut sebagai window wall, karena bentuknya yang terlihat seperti jendela.

*Curtain walls are non-structured walls that are used mostly for facing tall buildings. Curtain Wall also known as window walls due to their window shop.*



Fig. 1 Details of Curtain Wall

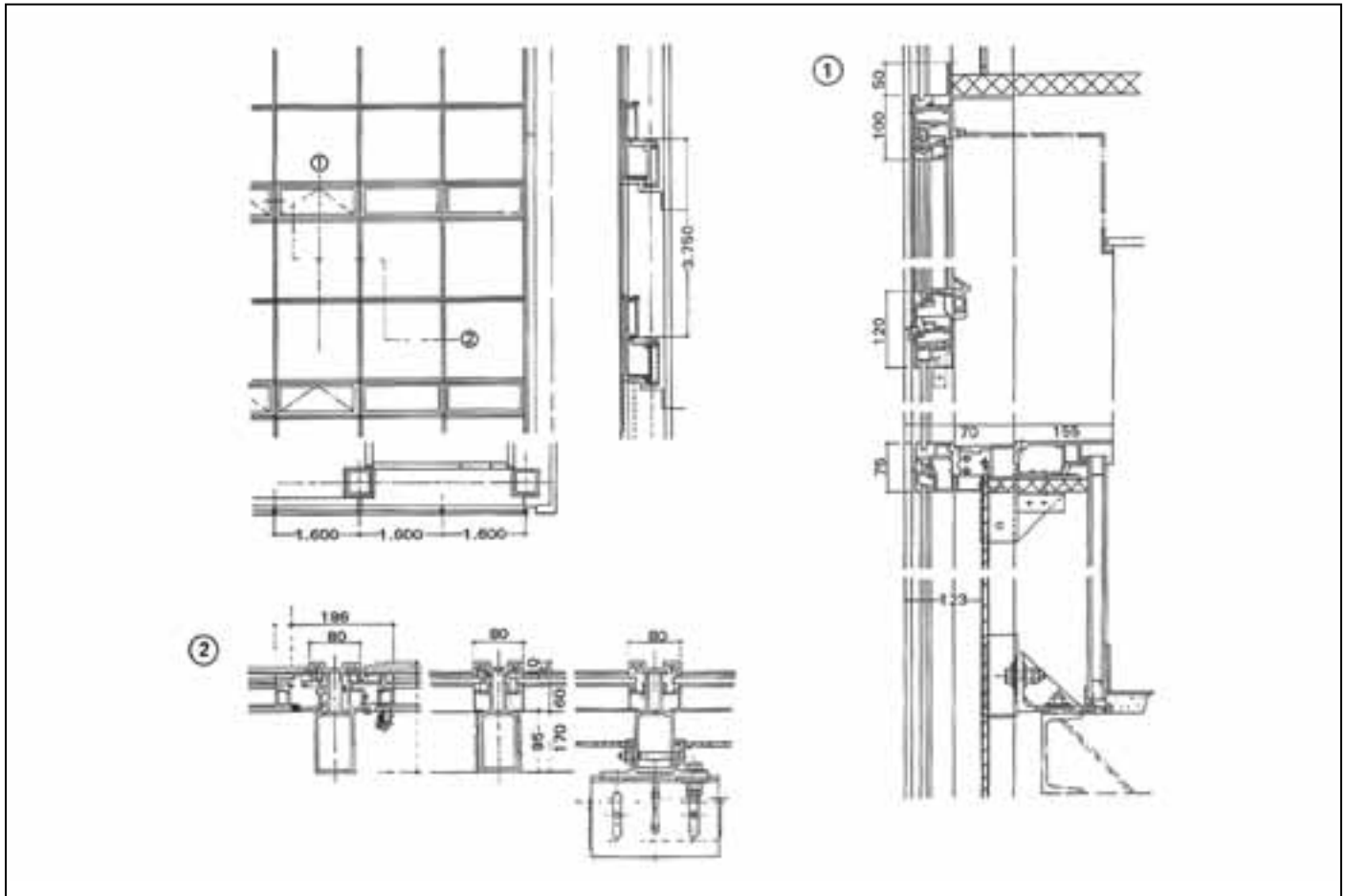
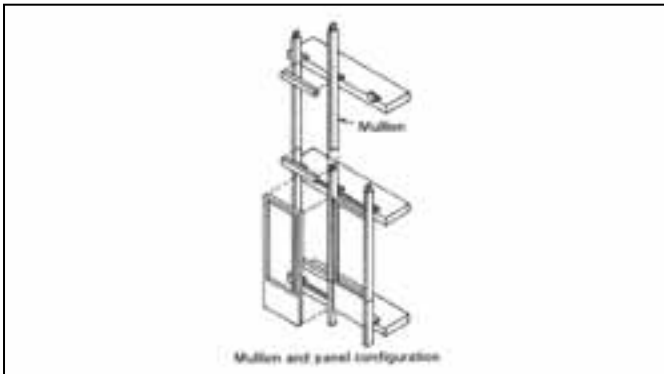

Fig. 2 Curtain Wall of Mullion Type



### Mullion Type

Pada type ini rangka-rangka untuk curtain wall dipasang pada mullion, dan mullion sendiri dipasang pada plat-plat lantai. Rangka curtain wall dapat dirakit di pabrik dan dipasang pada lokasi sebagai unit-unit tertentu (unit method) atau dapat pula dirakit di lokasi proyek (knock down atau stick method). Pada beberapa pemakaian mullion dapat dipasang setinggi beberapa plat lantai yang kemudian dibagi-bagi sebagai spandrel units dan sash units.

### Panel Type

Pada bagian ini rangka-rangka curtain wall dipasang dalam bentuk panel-panel yang langsung dipasang pada struktur lantai atau plat lantai. Besarnya panel ini bisa setinggi dua lantai sekaligus atau terdiri dari beberapa panel membentuk spandrel panel dan vision panel.

Fig. 3 Curtain Wall of Panel Type

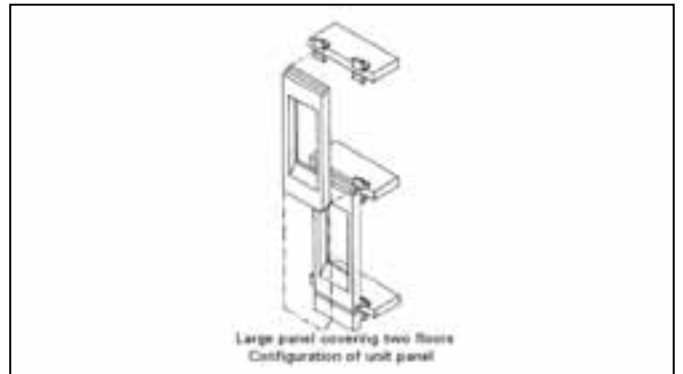

### Mullion Type

*In this type, frames for curtain walls are the attached to mullions, while the mullion themselves are attached to the floor. Curtain wall frames can be factory built and installed on site, ready made, or they can be built on site using knock-down method. In some applications, mullions can be set at several floor plates which can be divided as spandrel units and sash units.*

### Panel Type

*In this type, frames of curtain wall are fixed in panel forms and directly attached to the floor structures or plates. The dimensions of this panel can be as tall as two floors or consists of several panels forming spandrel panels and vision panels.*

## Catatan

- Mullion atau panel dari curtain wall dihubungkan menggunakan bracket dan fastener ke plat lantai.
- Bracket yang melekat pada mullion atau panel dipasangkan pada fastener yang diangkur dengan plat lantai melalui fastener lain (secondary fastener).
- Untuk menghindari pergeseran akibat gerakan bangunan, maka digunakan sliding mechanism dengan membuat lubang-lubang yang berbentuk memanjang pada fastener.

## Notes

- *Mullions or panels from curtain wall are attached to the floor by using brackets or fastener.*
- *Brackets that are attached to mullions or panels are fixed to fastener with a floor plan through another secondary fastener.*
- *To avoid friction due to building movement, a sliding mechanism is used by looping fastener with long holes.*

Fig. 4 Fasteners and Sliding Mechanism

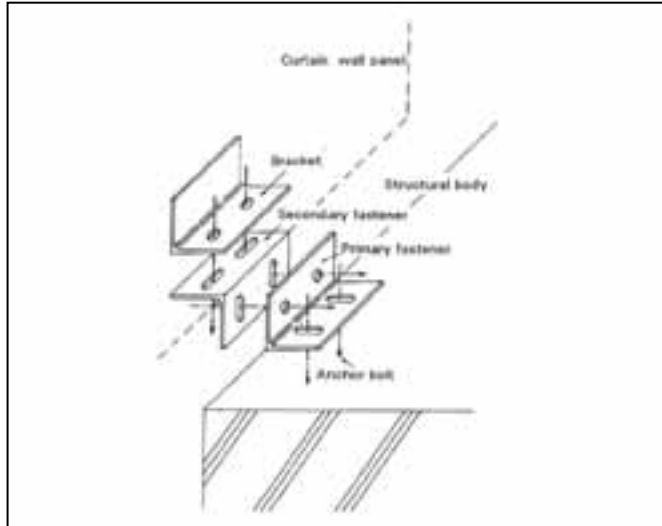



AGC Group

# GLACADE

Suspension Glass System

Perkembangan dari Glacade (Suspension Glass System) memungkinkan pemasangan dinding kaca yang luas dan besar yang diperlukan gedung-gedung model muktahir.

*The development of glacade has made a possibility in installation of high transparent and large opening which required in modern buildings.*



## Karakteristik Umum

- Memungkinkan diperoleh permukaan tegak yang ideal dan penampilan optis yang sempurna.
- Bebas dari tegangan dalam yang ditimbulkan karena adanya lenturan atau tegangan terpusat bila memakai sistim perletakan.
- Memungkinkan dipasangnya kaca berukuran besar dengan cara tersebut di atas (Hingga tinggi max. 10.49 m)
- Jika pecah bahayanya akan lebih kecil dibandingkan dengan cara konvensional karena bagian atasnya digantung.

## Jenis dan Spesifikasi

Ada 3 (tiga) jenis glacade yaitu Glacade SF, Glacade SM dan Glacade F, dimana masing-masing tergantung pada sistim penggunaannya dan pemasangannya. Glacade SF dan F mempunyai rib glass construction sebagai berikut:

- Oneseid-rib construction
- Bothside-rib construction
- Through-rib construction

Mekanisme penggantungan dari Glacade SF dan Glacade SM menggunakan hooks, rings, horseshoes shaped suspension units, taper plates dan sebagainya.

Spesifikasi dari tiap-tiap jenis dapat dilihat pada tabel-1.

Table-1 Types of Glacade

Type	Glacade Sf Type (Suspension, Frameless Construction)	Glacade SM Type (Suspension, Metal Mullion Construction)	Glacade F Type (Frameless Construction)
Suspension Mechanism	Suspending Both Face Plates and Rib Glasses from the Upper Structure	Suspending Face Plates from the Upper Structure	Support with Setting blocks at the Buttom, with No Suspension Mechanism
Mullion	Rib Glass	Metal Mullion	Rib Glass

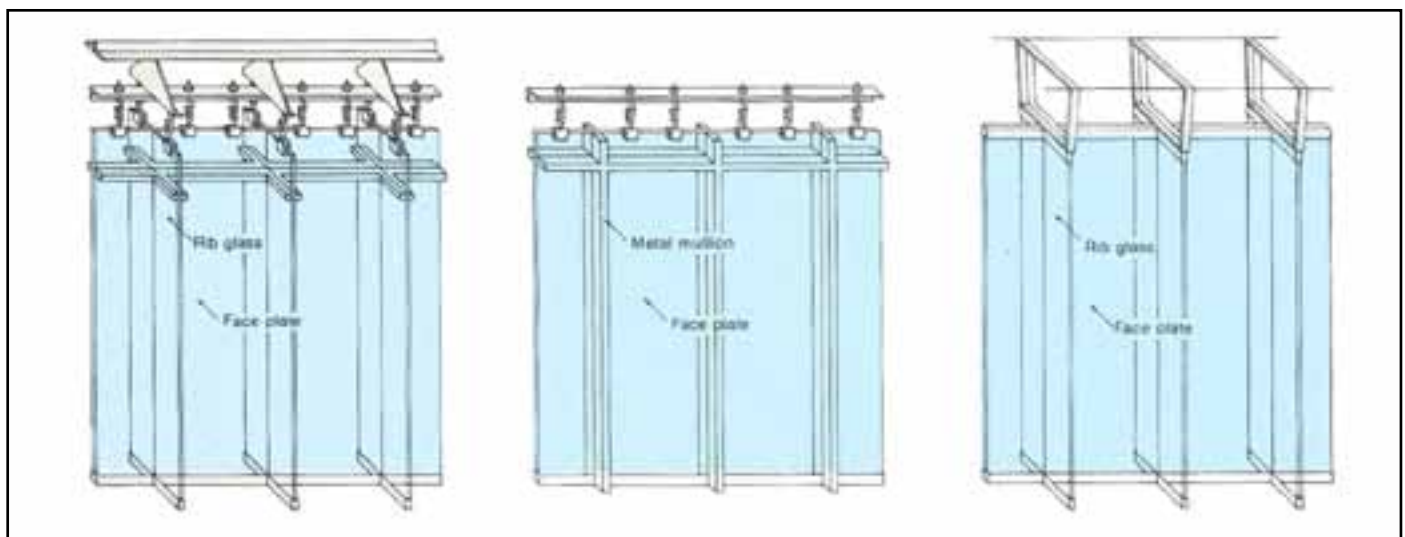

## Bahan-Bahan untuk Penggantung

### Hook

- Bahan Forged carbon steel (SF-40)  
**Horseshoe-Shaped Suspension Units**
- Bahan: Forged carbon steel (SF-46)
- Daya beban yang diijinkan:  
Jenis standar : 225 kg.  
Jenis besar : 600 kg

## Features

- *The suspension system creates ideal vertical surfaces, for undisturbed optical performance.*
- *These suspensions are free from inner stress from deflection, local stress, by setting blocks, etc.*
- *Larger glass than usual can be employed with these types (max. height 10.49 m).*
- *In case at breakage, they have a less danger of dropping than conventional glazing because their upper parts are suspended.*

## Type and Specifications

There are three types, Glacade SF, Glacade SM, and Glacade F available according to different glass supporting systems and construction methods. Glacade SF and Glacade F have the following rib glass construction:

- Oneseid-rib construction
- Bothside-rib construction
- Through-rib construction

The unique suspension mechanism of Glacade SF and Glacade SM use hooks, rings, horseshoe-shaped suspension units, taper plates etc.

The specifications of each type are shown in Table-1.



- Biasanya 2 (dua) Horseshoes-Shaped Suspension Units dipakai untuk menggantung satu lembar kaca, sehingga memungkinkan penggantungan sampai dengan berat 450 kg untuk jenis standard dan 1200 kg untuk jenis besar.

- *As two Horseshoe-shaped suspension units are usually used to suspend the glass weighing up to 450 kg for the standard type and 1200 kg for the large type.*

**Ring**

- Bahan: carbon steel untuk struktur mekanikal.
- Ring merupakan bagian utama untuk ketahanan terhadap gempa bumi, memberikan ketahanan terhadap gempa bumi, memberikan kemudahan dalam pekerjaan pemasangan Glacade SF dan SM, dan menyerap pergeseran relatif lantai bangunan sehingga kaca terhindar dari pengaruh daya gempa.

**Ring**

- *Material: Carbon steel for mechanical structure.*
- *Rings are very important components for earthquake resistance and installation performance of Glacade SF and Glacade SM absorbing the relative story displacement to prevent load to be imposed on the glass.*

**Taper Plate**

- Bahan: special nickel cast iron
- Sudut taper: 4/35
- Taper Plate dipasang pada bagian atas kaca dengan diberi suatu perekat epoxy khusus (a special epoxy adhesive). Kaca digantung dengan menggunakan taper plate dan Horseshoe-shaped suspension units.

**Taper Plate**

- *Material: Special nickel cast iron.*
- *Taper angle: 4/35*
- *The taper plate is installed on the top of the glass with a special epoxy adhesive. The glass is suspended with taper plates and Horseshoe-shaped suspension units.*

Figure-1 Types of Rib Glass Construction

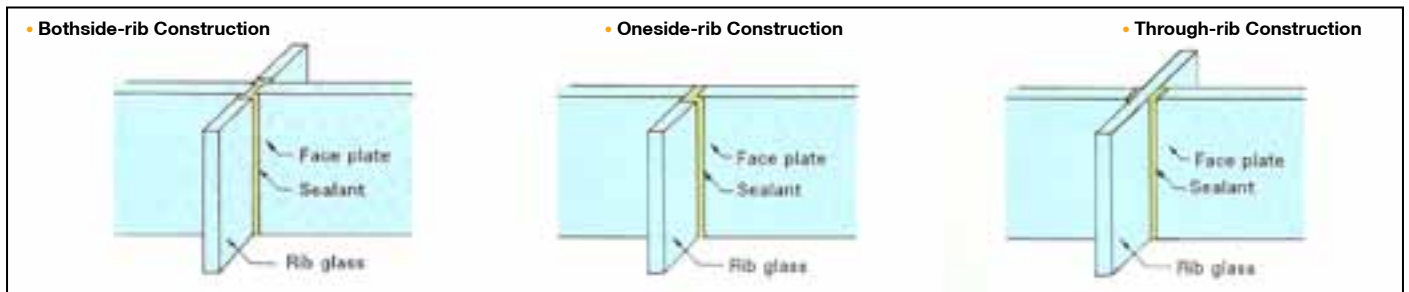
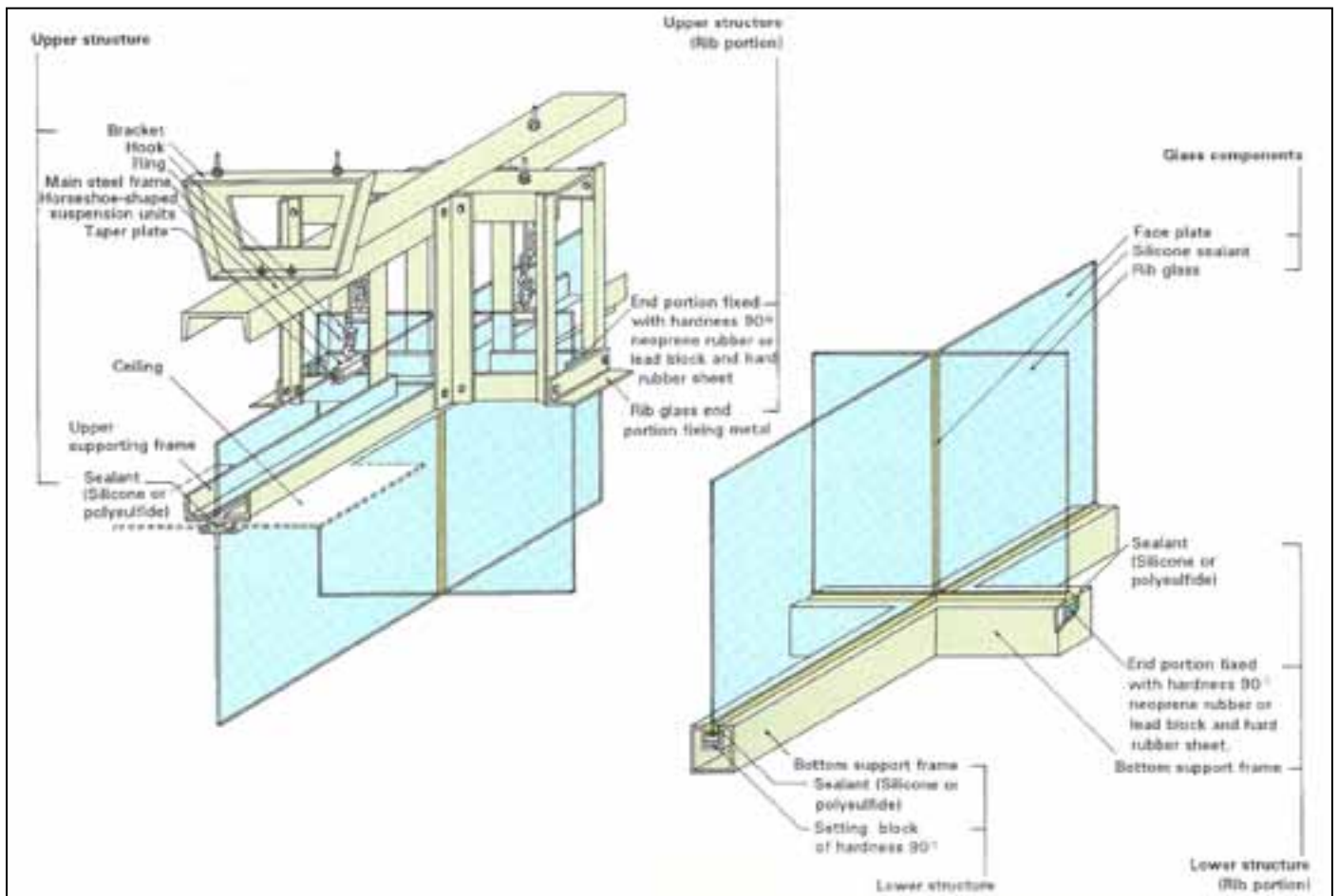

Figure-2 Diagram of Glacade SF



## Saran untuk Disain & Pemasangan

- Mengingat Glacade tergantung hanya pada kekuatan bahan penyekat organik, maka bahan ini harus dipilih dengan seksama.
- Pada Through-rib construction dan Single-rib construction bila bahan penyekat kurang baik, maka kaca yang hanya ditunjang pada kedua tepinya akan berkurang ketahanannya terhadap angin, oleh karena itu gunakanlah Bothside-rib construction.
- Butt-joint construction pada bagian sudut Glacade tidak disarankan, ditinjau dari sudut ketahanan terhadap gempa bumi. Mullion construction lebih cocok untuk hal tersebut di atas. Bila Butt-joint construction harus digunakan maka sisipkan karet neoprene antara kaca dengan rangka penyangganya dan harus ada jarak 10 mm antara kaca dengan kaca dan antara kaca dengan rangka penyangga.
- Bersihkan tepi kaca yang akan disambung dengan silikon dengan aceton, ketone atau ethyl alkohol untuk menghilangkan minyak, gemuk dan debu.
- Oleskan suatu lapisan tertentu sesuai dengan apa yang disyaratkan oleh pembuat bahan penyekat pada bagian kaca yang bersentuhan dengan silikon.
- Gunakanlah bahan penyekat silikon acetat yang bermodulus tinggi pada sambungan butt-joint.
- Hindarkanlah adanya gelembung udara atau cacat lainnya pada bagian penyekat.

## Pemeliharaan

- Periksalah bagian penyekat glacade secara berkala setiap 1-3 tahun sekali, tergantung pada faktor keamanan yang diperlukan pada bangunan tersebut.
- Bila terdapat goresan yang besar atau serpihan pada rib-glass, gantilah segera, bila tidak maka kekuatannya akan berkurang.

## Saran untuk Disain

- **Batas Lendutan Struktur**  
Pada jenis Glacade SF dan SM struktur atas menahan semua bahan dalam kaca dan perlengkapan logamnya. Bila struktur banyak melendut maka kaca akan bersentuhan dengan rangka penyangga bawah, sehingga menghilangkan fungsi glacade. Untuk menghindari hal tersebut di atas lendutan struktur maksimum 5 mm.
- **Ruangan yang Dibutuhkan pada Langit-Langit**  
Jenis penggantung (Glacade SF dan SM) membutuhkan ruangan pada langit-langit, akan dijelaskan di bawah untuk pemasangan mekanisme penggantung pada atas kaca.

**Ruang untuk Penggantung**  
(Min. 400 mm untuk standard;  
Min. 450 mm untuk yang besar)

+

**Ruang untuk Rangka Struktur**  
(Tergantung pada cara pemasangan)

- **Konstruksi Langit-Langit**  
Untuk pekerjaan pemasangan dan pemeliharaan, serta dengan memperhitungkan kemungkinan penggantian kaca, maka harus ada bagian langit-langit yang dapat dilepas untuk pemeriksaan kira-kira berjarak 500 mm dari kedua permukaan kaca.

## Design & Glazing Recommendation

- *As Glacade depend on strength of organic sealing materials, careful consideration must be paid to selection of the sealant.*
- *In the Through-rib construction and Single-rib construction, if sealing materials are defective, a glass supported only at two sides will have reduced wind resistance strength. Therefore, the use of Both side-rib construction at such places such as the lower stories of a very tall building and its surrounding areas, where wind pressure is expected to be high and both positive and negative wing pressure work on the glass.*
- *Butt-joint construction at corners of Glacade is not recommended from the point of view of earthquake resistance. Mullion construction is preferable for corners. If, however, Butt-joint construction have to be use, insert neoprene rubber between a glass and its support frame, and secure a joint of approximately 10 mm between glasses and between a glass and it's support frame.*
- *Clean the glass edge jointed with silicone well with aceton, ketone, or ethyl alcohol to remove oil, grease, and dust.*
- *Be sure to apply the primer specified by the sealing material manufacturer to the silicone joint portion of glass.*
- *Use a high modulus acetate silicone sealant at glass butt-joint.*
- *In the sealing work, be careful not to allow bubbles or other defects.*

## Maintenance

- *Inspect the sealing of Glacade periodically once every one to three years depending on the building to ensure its safety.*
- *If there is a large scratch or chip in Rib glass, replace it immediately otherwise, strength may be reduced.*

## Design Recommendation

- **Structural Deflection Limit**  
*In Suspension (type Glacade SF & SM), the upper structure bears the total weight of a large glass sheet and metal fittings. If the structure is deflected far, the glass comes in contact with its bottom support frame, losing the function of Glacade. To avoid this, keep structural deflection to 5 mm or less.*
- **Space Required in the Ceiling**  
*Suspension (types Glacade SF & SM), require space in the ceiling as described below for installation of the suspension mechanism at the top of the glass.*

**Space for Hanger**  
(400 mm or more for standard hangers;  
450 mm or more for larger hanger)

+

**Space for the Bracket and Structure Frame**  
(dependent on installation method)

- **Ceiling Construction**  
*For glazing work and maintenance and considering the possibility of glass replacement, provide a detachable inspection port in the ceiling in a range of approximately 500 mm off the both glass surfaces.*

- **Kekuatan dan Lentutan yang Diperkenankan pada Rangka Pendukung**

Rangka pendukung bagian atas adalah merupakan bagian yang penting dalam mencegah pemusatan tegangan pada penggantung dan pendukung bagian atas dari kaca untuk menahan tekanan angin. Rangka ini harus cukup kaku (ratio lentutan maksimum 1/300) dan kuat.

- **Kekuatan dan Lentutan yang Diperkenankan pada Rangka Mullion**

Pada Glacade SM, rangka logam mullion harus cukup kaku dan kuat untuk menahan tekanan angin. Ini berarti bahwa ratio lentutan maksimum harus 1/200 dan perubahan bentuk ratio lentutan maksimum 20 mm.

- **Bahan Rib Glass dan Pendukungnya**

Pasanglah kedudukan ujung bagian atas maupun bawah rib-glass dengan karet neoprene dengan kekerasan 90° atau balok timah hitam dan lembaran karet keras untuk mengurangi sekecil mungkin lentutan kaca karena tekanan angin.

- **Bahan Penyekat**

Pakailah bahan penyekat yang ditunjukkan di bawah ini, dan oleskan suatu lapisan tertentu seperti yang disyaratkan oleh produsen bahan penyekat.

Bagian	Penyekat
Butt-Joint Glazing	High-Modulus Acetate Silicon Sealant
Antara Kaca dan Rangka Pendukung	Silikon Bermodulus Rendah atau Menengah atau Penyakit Polisulfida

- **Strength and Allowable Deflection of Supporting Frame**

The upper supporting frames are important components in preventing concentration of stress on hangers and supporting the top of the glass against wind pressure. They require sufficient rigidity (deflection ratio: 1/300 or less) and strength.

- **Strength and Allowable Deflection on Mullion**

In Glacade SM, metal mullions require sufficient rigidity and strength against wind pressure. This means a deflection ratio of 1/200 or less and absolute deformation of 20 mm or less.

- **Material for Rib Glass and Support**

Fix both upper and lower ends of rib glass with neoprene rubber of hardness 90° or leadblock and hard rubber sheet, to minimize its displacement by wind pressure.

- **Sealing material Instruction**

Select sealant as shown below, and be sure to use the primers specified by the sealing material manufacturers.

Portion	Sealant
Butt-Joint Glazing	High-Modulus Acetate Silicon Sealant
Between Glass and Support Frame	Low or Middle-Modulus Silicone Sealant or Polysulfide Sealant

## Perhitungan kekuatan Glacade terhadap Tekanan Angin

### 1. Penentuan Tekanan Angin Rencana (P)

Karena cara perhitungan angin rencana berbeda untuk setiap negara, maka ikutilah perhitungan standard masing-masing negara untuk perhitungan ini.

### 2. Perhitungan Kekuatan Face Plate terhadap Tekanan Angin Rencana

Berdasarkan disain tekanan angin yang telah dihitung pada 1 di atas maka perhitungan kekuatan terhadap tekanan angin adalah sebagai berikut:

#### 2.1. Penentuan Beban Rencana (W)

$$W = P \times A$$

Dimana W = Beban rencana (kg)

P = Tekanan angin rencana (kg/m<sup>2</sup>)

A = Luas permukaan kaca (m<sup>2</sup>)

#### 2.2. Beban Ijin Kaca

Beban yang diijinkan untuk setiap tebal tercantum di bawah (diperoleh dari hasil percobaan)

Tebal Kaca (mm)	8	10	12	15	19
Beban Ijin (kg)	800	1000	1200	1700	2600

#### 2.3. Penetapan Tebal Kaca

Tetapkan tebal kaca dari table di atas supaya memenuhi hal tersebut di bawah:

$$\text{Beban rencana (W}_a) \leq \text{Beban ijin (W)}$$

## Calculation of Wind Pressure Resistance Strength for Glacade

### 1. Determination of Design Wind Pressure (P).

As the calculation methods of design pressure differ by country, follow the standards of each country for the calculation.

### 2. Calculation of Wind Pressure Resistance of Face Plate.

Based on the design wind pressure calculated in 1 the wind pressure resistance strength with following procedures:

#### 2.1. Determination of Design Load (W)

$$W = P \times A$$

Where W = Design load (kg)

P = Design wind pressure (kg/m<sup>2</sup>)

A = Area of glass (m<sup>2</sup>)

#### 2.2. Allowable Load of Glass (W<sub>a</sub>)

The allowable load of each thickness is as shown below (obtained from our experiments)

Glass Thickness (mm)	8	10	12	15	19
Allowable Load (kg)	800	1000	1200	1700	2600

#### 2.3. Selection of Glass Thickness

Select a glass thickness from the above table to meet the following:

$$\text{Design load (W)} \leq \text{Allowable load (W}_a)$$

### 3. Perhitungan Lebar Rib-glass

Lebar dari Rib-glass supaya dihitung sebagai berikut:  
 Pada Bothside-rib construction

$$X = \sqrt{\frac{W_F \cdot H_F^2 \cdot P}{480 t}}$$

Pada Oneside-rib construction/Through-rib construction

$$X = \sqrt{\frac{W_F \cdot H_F^2 \cdot P}{240 t}}$$

- $H_F$  = Tinggi Face plate (cm)
- $W_F$  = Lebar Face plate (cm)
- $P$  = Tekanan angin (kg/cm<sup>2</sup>)
- $t$  = Tebal rib-glass (cm)
- $X$  = Lebar rib-glass (cm)

#### Catatan

1. Gunakanlah Rib-glass dengan tebal 15 mm atau lebih supaya cukup kuat menjepit bidang kaca dinding.
2. Gunakanlah Rib-glass dengan lebar 100 mm atau lebih, mengingat keterbatasan dalam tehnik pemotongan kaca.

- **Tabel Ketebalan Kaca Glacade, pada Lantai Dasar**

Tabel-2 menunjukkan ketebalan Face plate dan ketebalan Rib-glass dalam hubungannya dengan dimensi Face plate, lebar Rib-glass dan tekanan angin rencana berdasarkan kekuatan kaca yang diperkenankan.

- **Syarat-Syarat Perhitungan**

1. Tekanan angin rencana dihitung pada bagian atas Face plate, dan minimum diambil 100kg/m<sup>2</sup>.
2. Koefisien tekanan angin C = 0,8
3. Beban yang diperkenankan pada kaca sesuai dengan hasil pengukuran kami.

### 3. Calculation of Rib-Glass Width

The Rib-glass width should be calculated as follows:  
 In Bothside-rib construction

$$X = \sqrt{\frac{W_F \cdot H_F^2 \cdot P}{480 t}}$$

In Oneside-rib construction

$$X = \sqrt{\frac{W_F \cdot H_F^2 \cdot P}{240 t}}$$

- $H_F$  = Height of Face plate (cm)
- $W_F$  = Width of Face plate (cm)
- $P$  = Wind pressure (kg/cm<sup>2</sup>)
- $t$  = Thickness of rib-glass (cm)
- $X$  = Width of rib-glass (cm)

#### Notes

1. Use Rib glass of thickness 15 mm or more to secure sufficient bite to Face plate.
2. Use Rib glass of width 100 mm or more in view of glass cutting.

- **Glass Thickness Table Glacade at the First Floor**

Table-2 shows Face plate thickness in relation to Face plate sizes, Rib glass width and the design wind pressures basing on the allowable strength of the glass.

- **Conditions for Calculation**

1. Design wind pressure: The wind pressure is calculated at the top of the Face plate height and the 100 kg/m<sup>2</sup> is Considered as minimum for Glacade.
2. Wind pressure coefficient C = 0.8
3. The allowable load of the glass conforms to our actual measurement.



### Catatan

1. Pada pemakaian Glacade untuk lantai 2 (dua) atau lebih tinggi, harap hubungi kami untuk penetapan jenis kacanya.
2. Kaca yang tercantum dalam kolom yang kosong dari tabel-2 tidak disarankan untuk digunakan bila ada tekanan angin.
3. Kaca bertanda O pada tabel-2 membutuhkan penggantung.
4. Rib glass disarankan dengan tebal 15 mm atau lebih untuk memperoleh jepitan yang cukup pada Face plate.
5. Rib glass disarankan dengan lebar 100 mm atau lebih mengingat cara/metode pemotongan kaca.
6. Bothside-rib glass harus dipakai bila kaca tercantum pada kolom [ ] dari Tabel-2.

#### ● Diagram Perhitungan Lebar Rib Glass

Figure-3 memperlihatkan diagram perhitungan lebar Rib Glass.

#### ● Cara Menggunakan Diagram

1. Berilah tanda pada garis (1) untuk nilai  $W_F$ , dan pada garis (2) untuk nilai  $H_F$  kemudian tarik garis antara kedua titik tersebut.
2. Perpanjang garis tersebut sampai memotong garis (3), kemudian tarik garis dari titik potong ini ke titik pada garis (4) yang menunjukkan nilai P (tekanan angin) memotong garis (5). Tarik garis dari titik pada garis (5) ini ke titik pada garis (6) yang menyatakan tebal Rib-glass. Perpanjang garis ini sampai memotong garis (7), dan didapati lebar Rib-glass yang harus digunakan.

### Catatan

1. Jika  $H_F < W_F$ , gunakan  $H_F$  sebagai pengganti  $W_F$ .
2. Bothside Rib pada garis (7) berarti kaca dengan ukuran yang sama harus dipasang masing-masing di luar dan di dalam; angka tersebut menunjukkan lebar satu lembar Rib glass.

### Notes

1. The applications of Glacade for a second or higher floor is required, please contact us for the selection of the glass.
2. Glass corresponding to a blank column in Table-2 not recommended for use in view of wind pressure strength.
3. Glass marked with O in the table requires suspension.
4. Rib glass of 15 m/m or thicker is recommended to secure sufficient bite with a Face plate.
5. Rib glass of 100 m/m or wider should be used because of the glass cutting method.
6. A bothside-rib glass installation should be employed for those enclose in [ ] in the Table-2.

#### ● Rib Glass width Calculation Chart

Figure-3 shows the Rib glass width calculation chart

#### ● Using the Calculation Chart

1. Marks points corresponding to  $W_F$  and  $H_F$  on lines (1) and (2) respectively, and draw a line between the points.
2. Extend the line and mark its point of intersection with line (3). Then draw a line between that intersection point and a point corresponding to P on line (4). Process this way to obtain a rib width on line (7).

### Notes

1. If  $H_F < W_F$ , use  $H_F$  instead of  $W_F$ .
2. Bothside Rib on line (7) means that one sheet each of the same size Rib glass is provided inside and outside, the numeral shows the width of one sheet of Rib glass.



Table-2 Glass Thickness Table for Glacade at The First Floor

Height of Face Plate	Design Wind Pressure (kg/m <sup>2</sup> )	Width of Face Plate															
		1.5 m				2.0 m				2.5 m				3.0 m			
		Thickness of Face Plate (mm)	Thickness of Rib Glass (mm)	Width of Rib Glass (cm)		Thickness of Face Plate (mm)	Thickness of Rib Glass (mm)	Width of Rib Glass (cm)		Thickness of Face Plate (mm)	Thickness of Rib Glass (mm)	Width of Rib Glass (cm)		Thickness of Face Plate (mm)	Thickness of Rib Glass (mm)	Width of Rib Glass (cm)	
				Both-side -rib	One-side -rib			Both-side -rib	One-side -rib			Both-side -rib	One-side -rib			Both-side -rib	One-side -rib
2.0 m	100.0	8	12	11	15	8	12	12	17	8	12	14	19	10	12	15	21
			15	10	13		15	11	15		15	12	17		15	13	19
2.5 m	100.0	8	12	13	18	8	12	15	21	10	12	17	24	10	12	18	26
			15	12	17		15	14	19		15	15	21		15	17	23
3.0 m	100.0	8	12	16	22	10	12	18	25	10	12	20	28	12	15	22	31
			15	14	20		15	16	23		15	16	23		19	18	25
4.0 m	100.0	10	12	21	29	10	12	24	34	12	12	27	38	15	12	29	41
			15	19	26		15	22	30		15	24	34		15	26	37
			19	17	23		19	19	27		19	21	30		19	23	33
5.0 m	107.3	10	15	24	34	12	15	28	39	15	15	31	44	15	15	34	48
			19	21	30		19	25	35		19	28	39		19	30	42
6.0 m	117.6	12	15	30	42	15	15	35	49	19	15	39	55	19	15	42	60
			19	27	38		19	31	44		19	35	49		19	38	53
7.0 m	127.0	15	15	36	51	19	15	42	59	19	15	47	66				
			19	32	46		19	37	53		19	42	59				
8.0 m	135.8	15	15	43	61	19	15	50	70								
			19	38	54		19	44	62								
9.0 m	144.0	19	15	50	70	19	15	57	81								
			19	44	62		19	51	72								
10.0 m	151.8	19	15	57	80												
			19	50	71												

Figure-3 Rib Glass Width Calculation Chart

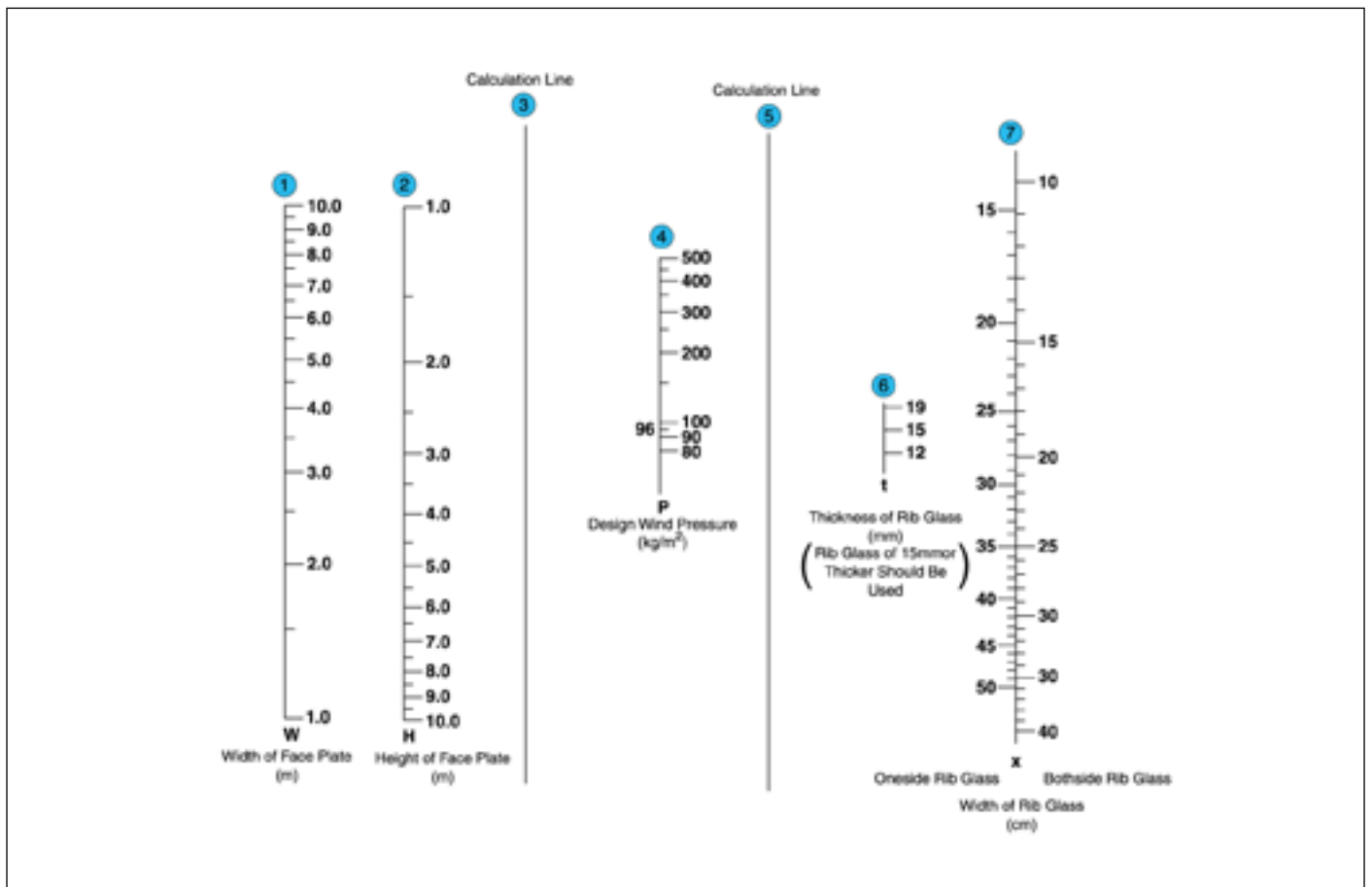
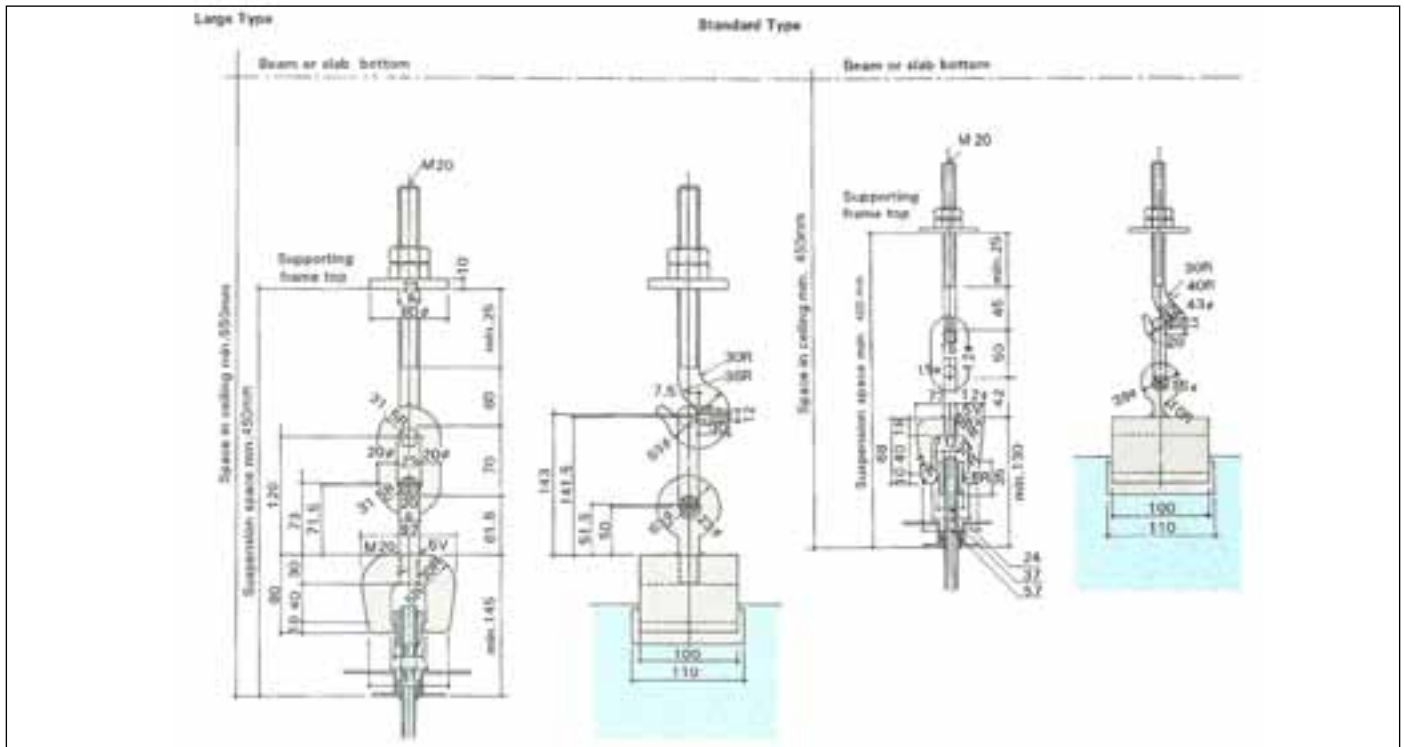
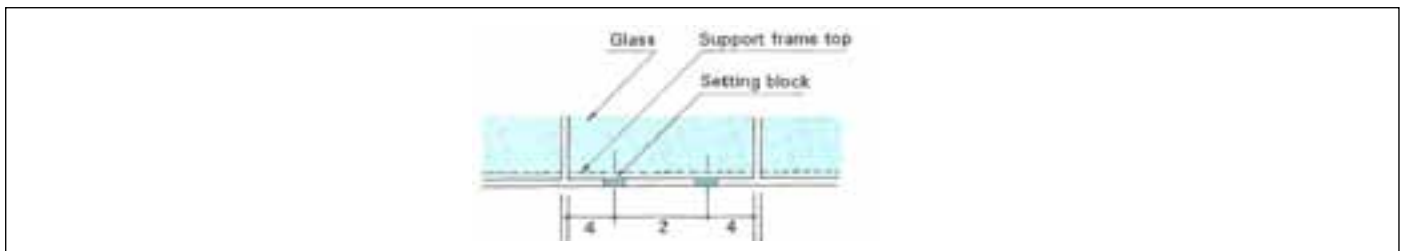

Figure-4 Hanger Details



Positions of Setting Blocks



### Pemilihan Jenis Penggantung dan Ruang Penggantung

Tentukan penggantung dan ruang penggantung berdasarkan berat kaca ( $W_g$ ) seperti dicantumkan pada tabel di bawah:

Berat Kaca	Jenis Penggantung	Ruang Penggantung
$W_g < 450 \text{ kg}$	Penggantung Standard	400 mm atau lebih
$1.200 \geq W_g \geq 450 \text{ kg}$	Penggantung Besar	450 mm atau lebih

#### Catatan

- Ruang yang diperlukan pada langit-langit untuk Glacade SF dan SM harus sebesar (ruang penggantung pada tabel di atas + ruang untuk rangka bracket dan struktur) lihat Figure-4.
- Hubungi kami bila ingin memakai kaca seberat  $W_g = 800 \text{ kg}$  atau lebih.

### Desain Balok Perletakan Glacade F

Untuk tipe F dimana berat kaca ditahan oleh balok perletakan di bagian bawah, bentuk dari balok harus ditentukan sedemikian rupa untuk menghindari kerusakan.

#### Bahan dan Posisi Pemasangan Balok Perletakan

Gunakanlah karet neoprene 90° untuk balok perletakan dan dipasang 2 (dua) buah pada posisi gambar berikut.

### Selection of Hangers and Suspension Spaces

Determine the type of hangers and Suspension Spaces from the glass weight ( $W_g$ ) as shown in the table below:

Glass Weight	Type of Hanger	Ruang Penggantung
$W_g < 450 \text{ kg}$	Standard Hangers	400 mm or more
$1.200 \geq W_g \geq 450 \text{ kg}$	Large Hangers	450 mm or more

#### Notes

- The space required in the ceiling for Glacade SF and SM should be (suspension space in the above table + space for the bracket and structural frame). Refer to Figure-4.
- Contact us before use if the weight of  $W_g = 800 \text{ kg}$  or more is applied.

### Design of Glacade F Setting Block

For F-types in which the glass weight is supported by setting blocks at the bottom, the shape of the blocks must be determined so as to avoid their ruin.

#### Material and Installation Position of Setting Blocks

Use neoprene rubber of hardness 90° as setting block and install two of them at the positions as shown in the figure below.

Figure-5 Accuracy of Passing Center In Upperepd Lower Support Frame

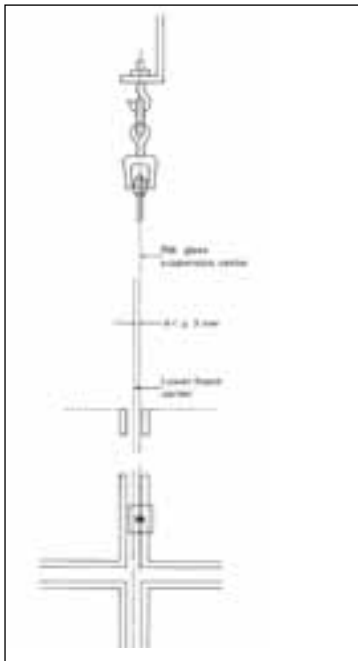

Glazing Details

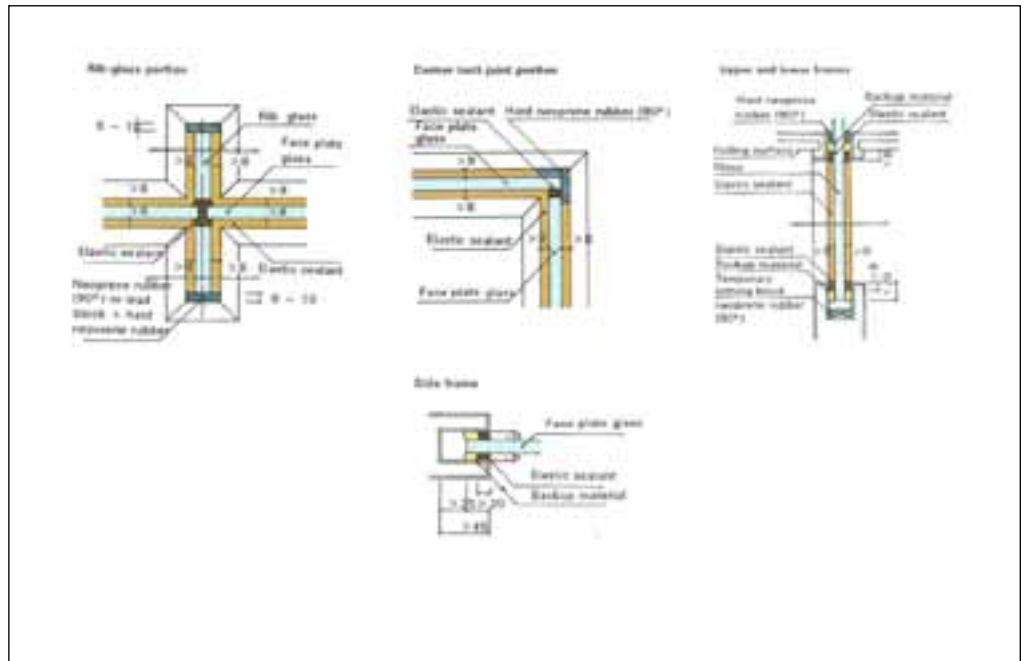

**Perhitungan balok perletakan**

Bentuk dan ukuran balok perletakan dihitung menurut persamaan di bawah ini:

**1. Panjang balok perletakan**

$$l = \frac{Wg}{10 \times t}$$

Dimana  $l$  = Panjang balok perletakan (cm)  
 $Wg$  = Berat kotor kaca (kg)  
 $t$  = Tebal kaca (cm)

**Setting Block Equation**

The shape and dimensions of a setting block are calculated by the following equation:

**1. Length of Setting Block**

$$l = \frac{Wg}{10 \times t}$$

Where  $l$  = Length of a setting block (cm)  
 $Wg$  = Gross weight of glass (kg)  
 $t$  = Tebal kaca (cm)

**2. Panjang balok perletakan**

Lebar (a) harus kira kira sama dengan alur rangka.

**3. Tebal balok perletakan (n)**

$b \leq a$  dimana  $b \geq 1.0$  cm



**2. Width of setting block**

Width (a) should be approximately the width of the frame groove.

**3. Thickness of setting block (n)**

$b \leq a$  where  $b \geq 1.0$  cm

**Ketebalan Penyekat Silikon**

Penyekat silikon yang ditempatkan antara kaca memegang peranan penting dalam konstruksi Glacade. Nilai-nilai di bawah ini disarankan sebagai tebal penyekat silikon.

Tebal penyekat silikon (mm) \ Rib glass (mm)	a	b	c
12	4	4	6
15	5	5	6
19	6	7	6

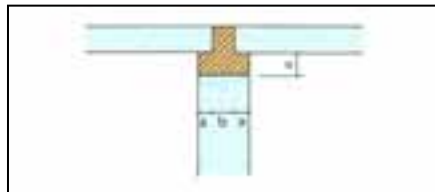

**Silicone Joints Thickness**

A silicone sealent between glasses plays an important role in Glacade constructions. The values below are recommended as the silicone joint thickness.

Silicone thickness (mm) \ Rib glass (mm)	a	b	c
12	4	4	6
15	5	5	6
19	6	7	6

**Ketelitian Glacade**

Karena Face Plate dan Rib Glass dipertemukan hanya dengan jarak yang kecil dan juga karena beberapa Glacade menggunakan mekanisme gantung maka perhatikanlah toleransi di bawah ini:

Bagian	Penyimpangan
Pusat Penggantung	± 1,5 mm
Pusat rangka pendukung atas dan bawah (lihat figure : 5)	± 3,0 mm

**Accuracy of Glacade**

As Glacade Face plates and Rib glass are butt-jointed with a little space allowed, and some Glacade uses a suspension mechanism, mainrain the following tolerances:

Portion	Deviation
Suspension Center	± 1,5 mm
Passing center in upper and lower support frames (Refer to figure : 5)	± 3,0 mm



## Detil Pemasangan

Gambar detil Glass Suspension System dijelaskan di halaman 28.

## Pemasangan Glacade SF & SM

(Lihat Figure-6)

### ● Struktur Atas

Glacade SF dan SM biasanya tergantung pada balok atau lantai bangunan di atasnya. Bila jarak antara dasar balok dengan langit-langit cukup besar, maka struktur atas digantung dengan memakai besi kanal yang kaku langsung ke balok. Suatu rangka pendukung atas diperlukan pada bagian atas kaca untuk menghindari pemusatan tegangan yang disebabkan oleh beban tekanan angin pada titik-titik penggantungan kaca.

Kaca dan rangka pendukung supaya disekat dengan penyekat elastid atau gasket yang dibentuk. Sisipkan karet neoprene dengan kekerasan 90° atau balok timah hitam dan karet keras di bagian pinggir atas dari rib glass dan pasanglah kaca sedemikian rupa untuk menekan deformasi seminimum mungkin akibat tekanan angin.

### ● Pemasangan bagian bawah

Rangka bawah, tidak seperti dinding-dinding tembus pandang pada umumnya, tidak dibutuhkan untuk menunjang berat kaca tetapi hanya untuk mencegah pergeseran arah mendatar karena tekanan angin dan sebagainya. Pasanglah bagian pinggir bawah rib glass seperti halnya pada bagian atas dengan karet neoprene dengan kekerasan 90° atau balok timah hitam dan lembaran karet keras.

## Mesin untuk Pemasangan

Teknik pengangkatan dan pemasangan glacade memegang peranan penting, terutama pada kaca berukuran besar. Mesin pemasangan memudahkan pekerjaan pemasangan sehingga hasilnya menjadi lebih aman dan lebih rapi.

## Urutan Kerja Glacade

Pekerjaan pemasangan glacade biasanya mengikuti urutan seperti tersebut di samping.

## Glazing Details

Standard Glazing methods of Glass Suspension System are as shown on page 28.

## Construction of Glacade SF and SM

(Refer to Figure-6)

### ● Upper Structure

Glacade SF and SM are usually suspended from a beam or an upper floor in a building. If, however, there is a long distance between the beam bottom and the ceiling, they are suspended from a highly rigid channel steel connected directly to the beam.

An upper support frame should be provided around the top of the glass to avoid concentration of stress by an external wind pressure load on the hanging points of the glass.

Seal glass and support frames with elastic sealant or formed gaskets. Insert neoprene rubber of hardness 90° or lead blocks and hard rubber sheets in the top of side edge of a Rib glass and fix the glass to minimize its deformation from wind pressure.

### ● Construction of Lower Portion

The lower frame, unlike that for general openings, is not required to support the weight of the glass, but only prevent horizontal displacement of the glass by wind pressure and so on. Fix the Rib glass lower side edge like the upper side edge with neoprene rubber of hardness 90° or lead blocks and hard rubber sheets.

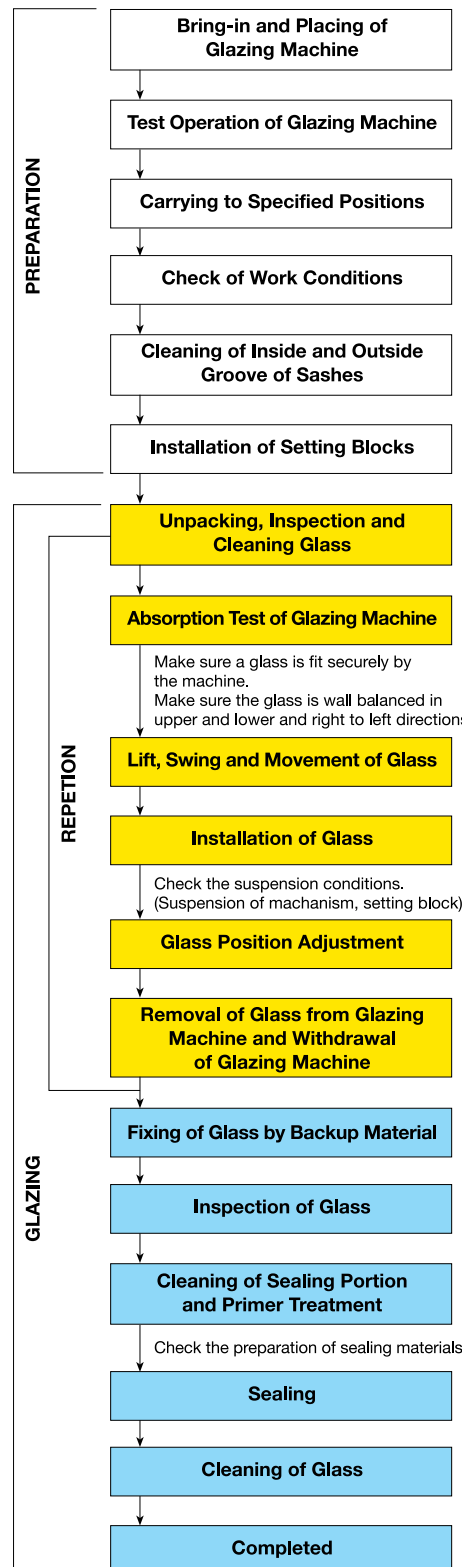

## Glazing Machine

The handling and glazing techniques of Glacade are important because of large glass sheets are used. A glazing machine will perform highly safe accurate glazing work for Glacade.

## Glass Suspension Work Order

The glazing work is generally performed in the order shown in the chart side.

Figure-6 Standard Details

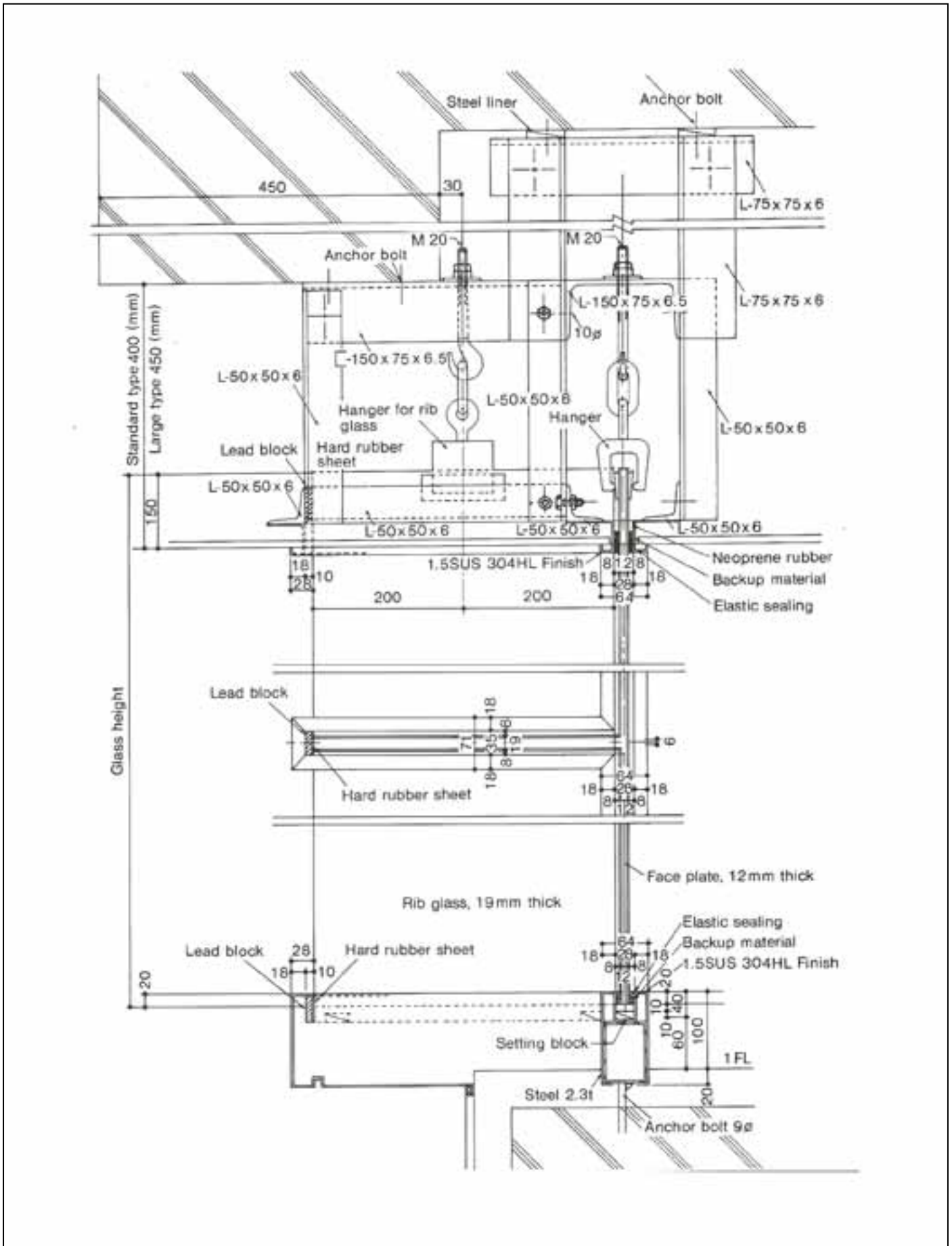



### Example of Glacade Design (Glacade SF)

#### *Nihonbashi Tokai Building*

Design by : Nikken Sekei Ltd.

Constructed by : Takenaka Komuten Co., Ltd,

Ohbayashi-Gumi, Ltd,

Toda Construction Co., Ltd

Glacade SF is used in the north entrance and east opening of Nihonbashi Tokai Building. It employs 15 mm-thick Float glass as Face plates and 19 mm-thick as Rib glasses. The magnificent-outer wall and transparent glass wall harmonized effectively, creating attractive space.

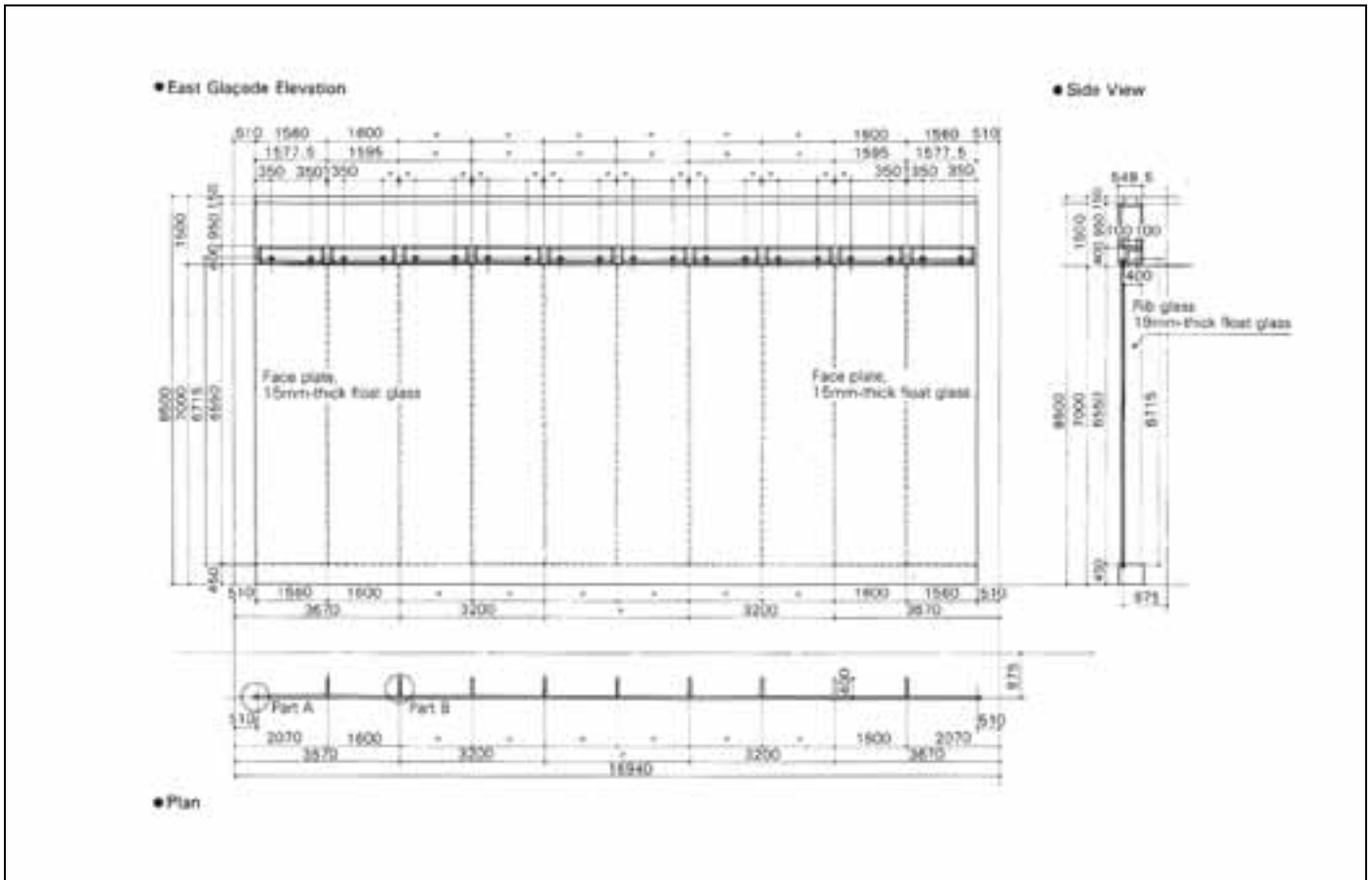



Table-1  
Sifat Fisik & Mekanik Kaca Physical & Mechanical Properties of Glass

Jenis Item	Nilai Values
Indeks Bias <i>Refractive Index</i>	Sekitar 1.52 <i>Approx 1.52t</i>
Indeks Pantulan (Cahaya Tegak Lurus)*1 <i>Reflectance (Vertical Incidence)*1</i>	Sekitar 4% Pada Tiap Permukaan <i>Approx 4% at Each Surface</i>
Panas Jenis <i>Specific Heat</i>	0.2 kcal/kg C (0° - 50°C) <i>0.2 kcal/kg C (0° - 50°C)</i>
Titik Lunak *2 <i>Softening Temperature *2</i>	720° - 730°C <i>720° - 730°C</i>
Konduksi Panas <i>Thermal Conductivity</i>	0.68 kcal/mhr°C <i>0.68 kcal/mhr°C</i>
Koefisien Muai Panjang <i>Coefficient of Linear Expansion</i>	8.5-9 x 10 <sup>-6</sup> /°C (Temp. Normal 350°C) <i>8.5-9 x 10<sup>-6</sup>/°C (Normal Temp. 350°C)</i>
Berat Jenis <i>Specific Gravity</i>	Sekitar 2.5 <i>Approx 2.5</i>
Kekerasan *3 <i>Hardness *3</i>	Sekitar 6 Derajat (Skala Mohs) <i>Approx 6 Degrees (Mohs Scale)</i>
Modulus Young <i>Young's Modulus</i>	720.000 kg/cm <sup>2</sup> <i>720.000 kg/cm<sup>2</sup></i>
Angka Poisson <i>Poisson's Ratio</i>	0.25 <i>0.25</i>
Tegangan Pecah Rata Rata *4 <i>Average Breaking Strees *4</i>	Sekitar 500 kg/cm <sup>2</sup> <i>Approx 500 kg/cm<sup>2</sup></i>
Daya Tahan Terhadap Cuaca *5 <i>Weather Resistance *5</i>	Tak Berubah <i>No Change</i>

Table-2  
Komponen Utama Kaca Main Components of Flat Glasses

Komponen <i>Component</i>	Isi <i>Content</i>	Keterangan <i>Remarks</i>
SiO <sub>2</sub>	70 - 74%	Komponen Utama <i>Main Component</i>
Al <sub>2</sub> O <sub>3</sub>	0 - 2%	Meningkatkan Elastisitas dan Kekuatan <i>Increasing Elastic Modulus &amp; Hardness</i>
CaO	6 - 12%	Membuat Kaca Tidak Cepat Larut Dalam Air <i>Making Glass Less Soluble In Water</i>
MgO	0 - 4%	
Na <sub>2</sub> O	12 - 16%	Menurunkan Titik Lebur <i>Lowering Melting Point</i>

Table-3  
Jenis-jenis Kaca & Pemakaiannya Kinds of Glasses & Their Applications

Jenis Kaca <i>Kind of Glass</i>	Pemakaian <i>Application</i>
Kaca Soda Lime <i>Soda Lime Glass</i>	Untuk Bangunan, Kendaraan, Botol <i>General Flat Glass for Building, Flat Glass for Vehicles, Bottles</i>
Kaca Potassium <i>Potassium Glass</i>	Untuk Peralatan Optik <i>Optical Equipment, Physical and Chemical Equipment</i>
Kaca Borosilicate (PYLEX) <i>Borosilicate Glass (PYLEX)</i>	Untuk Peralatan Optik, Fisika, Kimia dan Pecah Belah Tahan Panas <i>Optical Equipment, Physical and Chemical Equipment, Heat Resistant Tableware</i>
Kaca Quartz (BYCOL) <i>Quartz Glass(BYCOL)</i>	Untuk Pecah Belah Tahan Panas dan Peralatan Peralatan Tahan Panas <i>Heat Resistant Tableware, Heat Resistant Equipment</i>
Kaca Lead <i>Lead Glass</i>	Peralatan Medis <i>Medical Equipment</i>

## Sifat Fisik dan Kimia Bahan Lain Physical and Chemical Properties of Other Materials

Indeks Bias Refractive Index

Air <i>Water</i>	Bensin <i>Benzine</i>	Kristal <i>Crystal</i>	Intan <i>Diamond</i>
1.33	1.50	1.54	2.42

Panas Jenis (kcal/kg°C) Specific Heat (kcal/kg°C)

Baja <i>Steel</i>	Granit <i>Granite</i>	Aluminium <i>Aluminum</i>	Polikarbonat <i>Polycarbonate Sheet (LEXAN)</i>	Air <i>Water</i>
0.11	0.2	0.22	0.26-0.28	0.99

Konduksi Panas (kcal/mhr°C) Thermal Conductivity (kcal/mhr°C)

Aluminium <i>Aluminum</i>	Baja <i>Steel</i>	Karet <i>Rubber</i>
190	41	0.33

- \*1 Cahaya yang mengenai kaca dipantulkan oleh kedua permukaannya. Pantulan pada setiap permukaan sekitar 4%. Untuk kaca polos jumlah pantulan sekitar 8% karena hanya sebagian kecil cahaya diabsorpsi oleh kaca tersebut. Cahaya yang arahnya menyudut, pantulannya lebih besar.
- \*2 Metode pengukuran berdasarkan ASTM C338-57. Kaca tidak mempunyai titik lebur tertentu, tetapi kekentalannya akan menurun dengan kenaikan suhu. Suhu pelunakan pada 720°-730°C adalah suhu pada kekentalan 4,5 x 10<sup>7</sup> poise.
- \*3 Skala Mohs  
Apatite : 5 derajat Feldspar : 6 derajat Quartz : 7 derajat
- \*4 Kaca biasanya akan pecah bila mengalami tegangan pada permukaannya
- \*5 Permukaan kaca tidak mungkin bebas dari cacat mikroskopis, namun tidak berpengaruh terhadap struktur dalamnya.  
Catatan: Nilai-nilai tersebut di atas merupakan nilai rata-rata kaca pada umumnya.

Koefisien Muai Panjang (x10-6/°C) Coefficient of Linear Expansion (x10-6/°C)

Polikarbonat <i>Polycarbonate Sheet (LEXAN)</i>	Aluminium <i>Aluminum</i>	Tembaga <i>Cooper</i>	Baja <i>Steel</i>	Kayu <i>Wood</i>
68	23	16	11	5-8

Berat Jenis (Tanpa Unit) Specific Gravity (No Unit)

Baja <i>Steel</i>	Intan <i>Diamond</i>	Polikarbonat <i>Polycarbonate Sheet (LEXAN)</i>	Kayu Pinus <i>Phe Tree Japanese Ceder</i>
7.9	3.5	1.2	0.5

Modulus Young (kg/cm<sup>2</sup>) Young's Modulus (kg/cm<sup>2</sup>)

Baja <i>Steel</i>	Aluminium <i>Aluminum</i>	Beton <i>Concrete</i>	Polikarbonat <i>Polycarbonate Sheet (LEXAN)</i>
2.100.000	700.000	200.000	21.000-25.000

- \*1 Rays are reflected by both surfaces of glass. The reflectance on one surface is approximately 4%. In the case of a clear glass therefore the reflectance per glass is approximately 8% because little rays are absorbed inside the glass. Oblique incidence increases the reflectance.
- \*2 Measurement values by ASTM C338-57  
Glass has no specific melting part, but its viscosity decrease continuously with the increase of temperature. The value in the table is the temperature showing a viscosity of 4,5 x 10<sup>7</sup> poise.
- \*3 Mohs scale  
5 degrees : Apatite 6 degrees : Feldspar 7 degrees : Quartz
- \*4 Glass is always broken by tensile stress on its surface
- \*5 It cannot be said that glass surfaces are free from flaws and weathering. However, the internal structure is not appreciably altered.  
Note: The values in the above table are general values showing physical and mechanical properties and not performance guarantees for each product.



AGC Group

# 2. TECHNICAL CHARACTERISTIC

## INDOFLOT AND PANASAP

Type Of Glass	Standard Thickness (mm)	Energy Characteristic				LightCharacteristic		Shading Coefficient *3*4	Solar Factor (%)	U Value W/m2k
		Transmittance (%)	Reflectance (%)	Absorption (%)	Ultra Violet Transmission (%)	Transmittance (%)	Reflectance (%)			
Indoflot Clear (FL)	2	87	7	5	78	91	8	1.01	88	6.0
	3	85	7	8	73	90	8	1.00	87	5.9
	4	83	7	10	69	90	8	0.99	86	5.9
	5	81	7	12	65	89	8	0.97	84	5.8
	6	79	7	14	62	89	8	0.95	83	5.8
	8	75	7	18	58	88	8	0.93	81	5.7
	10	72	7	22	53	87	8	0.90	78	5.7
	12	69	6	25	50	86	8	0.87	76	5.6
	15	64	6	30	45	84	7	0.84	73	5.5
19	59	6	35	40	83	7	0.80	70	5.4	
Panasap Bronze (BRFL)	5	56	5	39	25	55	5	0.77	67	5.8
	6	50	5	44	20	50	5	0.73	64	5.8
	8	41	5	54	14	41	5	0.66	58	5.7
Panasap Dark Grey (DGFL)	3	52	5	43	55	38	5	0.74	65	5.9
	4	43	5	52	49	28	4	0.67	59	5.9
	5	36	5	59	44	21	4	0.62	54	5.8
	6	31	4	65	40	15	4	0.58	50	5.8
Panasap Green (GNFL)	5	43	5	52	24	74	7	0.67	58	5.8
	6	38	5	57	20	70	6	0.63	55	5.8
	8	30	5	65	14	64	6	0.58	50	5.7
	10*	25	5	70	10	59	6	0.54	47	5.7
	12	21	4	74	7	54	6	0.51	44	5.6
Panasap EuroGrey (GEFL)	4	57	5	38	32	56	6	0.78	68	5.9
	5	50	5	45	26	49	5	0.73	63	5.8
	6	44	5	51	22	43	5	0.68	59	5.8
	8	35	5	61	15	34	5	0.61	53	5.7
	10*	27	4	68	11	26	5	0.55	48	5.7
	12	21	4	75	8	20	4	0.51	45	5.6
Panasap Blue Green (BNFL)	5	44	5	51	28	66	6	0.68	59	5.8
	6	39	5	56	24	62	6	0.64	56	5.8
	8	31	5	64	17	55	6	0.58	51	5.7
Panasap Dark Blue (DHFL)	5	50	5	45	35	62	6	0.72	63	5.8
	6	44	5	51	31	58	6	0.68	59	5.8
	8	36	5	60	24	49	5	0.61	54	5.7
	10*	29	5	67	19	42	5	0.56	49	5.7
	12	23	4	72	15	36	5	0.53	46	5.6
Panasap Light Green (LNFL)	2	73	6	20	55	86	7	0.91	79	6.0
	3	65	6	28	45	83	7	0.85	73	5.9
	4	59	5	35	38	81	7	0.80	69	5.9
	5	53	5	41	33	78	6	0.76	65	5.8
	6	48	5	46	28	76	6	0.72	62	5.8
	8	40	5	54	22	71	6	0.66	57	5.7
	10	34	4	60	17	66	6	0.62	53	5.7
	12	30	4	65	13	62	5	0.59	50	5.6

## PLANIBEL G

Type Of Glass	Standard Thickness (mm)	Coating Position	Energy Characteristic				LightCharacteristic		Shading Coefficient *3*4	Solar Factor (%)	U Value W/m2k
			Transmittance (%)	Reflectance (%)	Absorption (%)	Ultra Violet Transmission (%)	Transmittance (%)	Reflectance (%)			
Planibel G	3.2	#2	70	10	20	55	82	11	0.84	73	3.7
	4	#2	68	10	22	53	82	11	0.83	72	3.7
	5	#2	67	10	23	51	81	10	0.81	71	3.7
	6	#2	66	10	25	47	80	10	0.80	70	3.7

## STOPSOL

Type Of Glass	Standard Thickness (mm)	Coating Position	Energy Characteristic				LightCharacteristic		Shading Coefficient *3*4	Solar Factor	U Value W/m2k
			Transmittance (%)	Reflectance (%)	Absorption (%)	Ultra Violet Transmission (%)	Transmittance (%)	Reflectance (%)			
Stopsol Supersilver Green (SSGN)	5	#1	35	18	47	14	56	27	0.53	46	5.8
		#2	35	11	54	14	56	20	0.56	49	5.8
	6	#1	31	18	50	13	54	27	0.53	46	5.8
		#2	31	10	59	13	54	19	0.56	49	5.8
	8	#1	24	18	58	7	49	26	0.48	42	5.7
		#2	24	8	68	7	49	15	0.52	45	5.7
Stopsol Supersilver Dark Blue (SSDH)	5	#1	38	20	41	22	46	29	0.58	51	5.8
		#2	38	11	51	22	46	17	0.61	54	5.8
	6	#1	34	20	46	20	43	29	0.54	47	5.8
		#2	34	10	56	20	43	15	0.58	51	5.8
	8	#1	27	20	53	16	37	28	0.50	43	5.7
		#2	27	8	65	16	37	12	0.54	47	5.7
Stopsol Supersilver Euro grey (SSGE)	6	#1	39	20	41	15	33	28	0.58	51	5.8
		#2	39	9	53	15	33	10	0.62	54	5.8
	8	#1	31	18	50	9	26	26	0.53	46	5.7
		#2	31	7	62	9	26	7	0.58	50	5.7
Stopsol Supersilver BlueGreen (SSBN)	6	#1	31	19	50	16	48	27	0.53	46	5.8
		#2	31	9	60	16	48	16	0.56	49	5.8
	8	#1	25	18	57	12	44	26	0.49	43	5.7
		#2	25	8	67	12	44	13	0.53	46	5.7
Stopsol Supersilver Clear (SSFL)	6	#1	67	20	13	40	69	28	0.82	71	5.8
		#2	67	18	15	40	69	27	0.83	72	5.8
	8	#1	64	20	15	39	67	29	0.79	68	5.7
		#2	64	17	19	39	67	27	0.80	69	5.7
Stopsol Classic Green (CGN)	5	#1	24	24	52	15	32	32	0.45	39	5.9
		#2	24	10	66	15	32	18	0.51	44	5.9
	6	#1	21	24	54	7	31	32	0.43	37	5.8
		#2	21	9	70	7	31	17	0.49	42	5.8
	8	#1	15	26	59	4	27	32	0.38	33	5.7
		#2	15	8	76	4	27	16	0.45	39	5.7
Stopsol Classic Dark Blue (CDH)	5	#1	26	26	48	11	26	33	0.46	40	5.8
		#2	26	10	64	11	26	16	0.52	45	5.8
	6	#1	23	25	53	10	24	31	0.44	38	5.8
		#2	23	10	67	10	24	14	0.50	43	5.8
	8	#1	18	25	57	8	20	31	0.40	35	5.8
		#2	18	8	74	8	20	11	0.46	40	5.8
Stopsol Supersilver Dark grey (SSDG)	5	#1	30	21	49	29	15	29	0.51	45	5.9
		#2	30	7	63	29	15	6	0.56	49	5.9

## INDOFIGUR

Type Of Glass	Standard Thickness (mm)	Coating Position	Energy Characteristic				LightCharacteristic		Shading Coefficient *3*4	Solar Factor	U Value W/m2k
			Transmittance (%)	Reflectance (%)	Absorption (%)	Ultra Violet Transmission (%)	Transmittance (%)	Reflectance (%)			
Non Reflective (NR)	2	#1	87	7	6	75	91	8	1.02	88	5.9
		#2	87	7	6	75	91	8	1.02	88	5.9
Mislite (FM)	3	#1	81	6	12	66	87	7	0.97	85	5.9
		#2	81	7	12	66	87	7	0.97	85	5.9
	5	#1	80	6	14	64	88	7	0.96	84	5.8
		#2	80	7	13	64	88	8	0.96	84	5.8
Figure Flora (FF)	3	#1	81	5	14	68	86	6	0.97	85	5.9
		#2	81	6	13	68	86	6	0.97	85	5.9
Gold Fish (GF)	3	#1	82	7	11	68	88	7	0.98	85	5.9
		#2	82	7	10	68	88	8	0.98	85	5.9

## SUNERGY

Type Of Glass	Standard Thickness (mm)	Coating Position	Energy Characteristic				LightCharacteristic		Shading Coefficient "J"4	Solar Factor (%)	U Value W/m2k
			Transmittance (%)	Reflectance (%)	Absorption (%)	Ultra Violet Transmission (%)	Transmittance (%)	Reflectance (%)			
Sunergy Clear (SNFL)	3	#2	53	10	37	50	70	7	0.70	60	4.2
	4	#2	52	10	38	47	70	7	0.68	59	4.2
	5	#2	52	10	38	48	69	7	0.67	59	4.1
	6	#2	51	9	40	44	69	7	0.67	59	4.1
	8	#2	49	9	42	42	68	7	0.65	57	4.1
	10	#2	47	8	45	38	67	6	0.64	56	4.1
Sunergy Green (SNGN)	6	#2	27	6	67	16	56	6	0.47	41	4.1
	8	#2	23	6	71	12	52	6	0.43	37	4.1
Sunergy Blue Green (SNBN)	6	#2	25	6	69	17	48	6	0.45	39	4.1
	8	#2	21	5	74	13	42	5	0.41	35	4.1
Sunergy Euro Grey (SNGE)	6	#2	28	6	66	15	33	5	0.47	41	4.1
	8	#2	22	6	72	11	25	5	0.41	36	4.1

### Remarks:

- Data dihitung menggunakan pengukuran spektral berdasarkan standar EN 410 (1998), ISO 9050, WIS/WINDAT, Illuminant A observer 20 CIE 1931
- Energi berdasarkan ISO/DIS 9050 NFRC 100-2001 dan/atau EN 410
- U value dihitung berdasarkan standard ISO EN 673 dan/atau kondisi NFRC 100-2001
- Transmisi Ultra violet berdasarkan ISO/DIS 9050 tabel 4, DIN 67507 clause 6 tabel 4, pr-EN 410 tabel 3 (280nm-380nm)
- Dokumen ini bukan merupakan evaluasi dari resiko kepecahan kaca dikarenakan thermal stress. Untuk kaca tempered resiko dari kepecahan yang disebabkan Nickel Sulfida tidak dilindungi oleh PT Asahimas Flat Glass Tbk, Tes Heat Soak dapat dilakukan sesuai permintaan
- Spesifikasi, teknikal dan data lain pada informasi yang ditampilkan pada dokumen ini dapat berubah tanpa pemberitahuan sebelumnya. PT Asahimas Flat Glass Tbk tidak bertanggung jawab jika terjadi penyimpangan antara antara data yang dijelaskan dengan kondisi di lapangan.

### Remarks:

- The data calculated using spectral measurements that are conform to standards EN 410 (1998), ISO 9050, WIS/WINDAT, Illuminant A observer 2° CIE 1931.
- Energy properties according to ISO/DIS 9050, NFRC 100-2001 and/or EN 410
- U value (formerly k-value) is calculated according to standard ISO EN 673 and/or NFRC 100-2001 conditions.
- Ultra Violet Transmittance according ISO/DIS 9050 table 4, DIN 67507 clause 6 table 4, pr-EN 410 table 3 (280nm-380nm)
- This document is no evaluation of the risk of glass breakage due to thermal stress. For tempered glass: the risk of spontaneous breakage due to Nickel-Sulfide this not covered by PT Asahimas Flat Glass Tbk. The Heat Soak Test is available on request.
- Specification, technical and other data are based on information available at the time of preparation of this document and are subject to change without notice. PT Asahimas Flat Glass Tbk. can not be held responsible for any deviation between the data introduced and the conditions on site. This document is only informative, in no way it implies an acceptance of the order by PT Asahimas Flat Glass Tbk.



# 3. THE THERMAL CRACK OF WINDOW GLASS PARTICULARLY WITH RESPECT TO PANASAP

Figure-1 The Thermal Crack

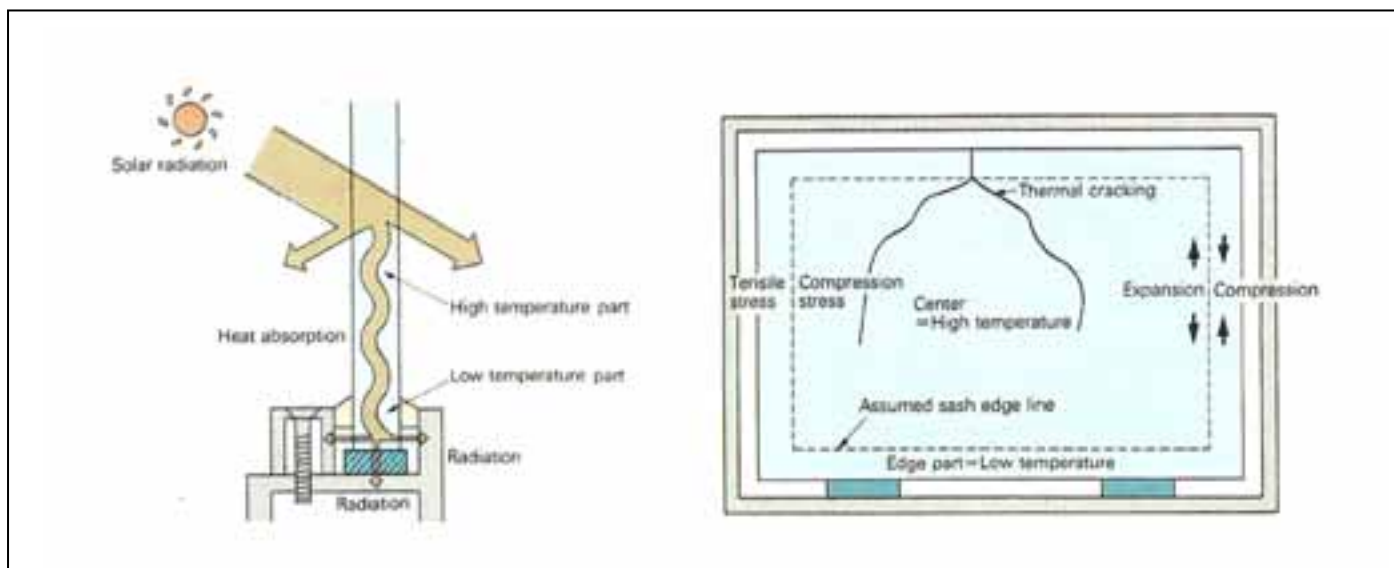

Apabila jendela kaca, terutama Panasap (dark grey), langsung terkena sinar matahari, dimana energi panas matahari banyak diserap (hingga kurang lebih 50%), maka bagian kaca tersebut relatif lebih cepat panas dan memuai dibandingkan dengan pemanasan dan pemuaian pada bagian tepi/sisi kaca yang terlindung rangka. Perbedaan ini mengakibatkan timbulnya tegangan dalam kaca, dan jika tegangan ini mengejutkan kekuatan kaca pada bagian tepinya, maka kaca akan retak dan disebut sebagai Thermal Crack.

## Pertimbangan Desain

- Perlu diperhatikan bahwa ukuran lembaran kaca yang besar dan tebal (dimana dengan pertimbangan ketahanan terhadap daya angin maka dipakai kaca-kaca tebal) akan lebih tinggi tingkat penyerapan panasnya.
- Pemakaian kaca sebagai spandrel, dimana biasanya dipasang pada beton-beton struktur yang memungkinkan terjadinya akumulasi panas, perlu diperhatikan jenis dan ketebalan kacanya.
- Hindari outlet pengkondisian udara yang menyemburkan udara langsung ke permukaan kaca secara terus menerus dalam waktu lama.
- Pengecatan dan penempelan kertas/film dekorasi pada kaca akan meningkatkan daya serap kaca terhadap panas.
- Hindari pemotongan kaca yang kurang baik seperti tepi-tepi kaca yang kasar, bergerigi. Untuk hasil yang baik gunakan mesin gosok tepi kaca (sander) dengan tingkat 120 mesh.

When window glass, particularly heat absorbing glass, is exposed to sunshine, the glass absorbs solar energy. The glass area warms rapidly and expands, reaching a very high temperature. In the other hand, such solar energy does not directly reach the glass edge which is shaded and covered by sash. In due course, the edge of the glass receives less heat than the sunlit area. As a result, the thermal expansion of the sunlit area is suppressed at the glass edge and creates tensile stress which is produced by thermal differential develops at the edge. When this tensile stress surpasses the strength of the glass edge, the thermal crack may occur. This type of cracking is referred to as Thermal Crack.

## Design Consideration

- Need an extra attention when using a big and thick glass sheet (a consideration against the wind resistance strength). Using thicker glass is an ideal in order to enhance heat absorbing nature of glass.
- Using glass as spandrel where usually installed in the structure concrete will possibly enhance heat accumulation. Therefore, thickness and typical glass attentively need an extra care for this usage.
- Avoid direct continous contact with heavy air blow towards glass surface for a long period of time.
- Using paint or paper/film stickers as a decoration may enhance heat absorbing on glass.
- Avoid rough glass cutting, chipping, or little crack on the edges. Use glass sander wih 120 mesh level in order to get good quality.

# 4. WIND PRESSURE RESISTANCE STRENGTH

## Beban yang diizinkan untuk setiap jenis kaca lembaran

Tekanan angin akan mengurangi kekuatan kaca lembaran. Kekuatan pada setiap kaca dapat diukur melalui percobaan/tes kepecahan. Tekanan angin rata-rata pada setiap ketebalan kaca pada Tabel-1 diperoleh secara statistik dari nilai yang telah diukur dari nilai kepecahan puluhan kaca dan standar deviasi kaca. Beban rata-rata (kg) diperoleh dari mengalikan tekanan angin rata-rata (kg/m<sup>2</sup>) dengan luas permukaan kaca (m<sup>2</sup>)

Nilai tekanan angin rata-rata (kg/m<sup>2</sup>), dihitung dengan membagi besaran beban rata-rata (kg) dengan luas permukaan kaca (m<sup>2</sup>). Tingkat kegagalan untuk 1 berbanding 1000 pada beban rata-rata (kg), dapat diartikan bahwa terdapat kemungkinan kepecahan pada setiap 1 dari 1000 lembar kaca jika beban rata-rata (kg) bekerja pada semua lembar kaca.

## Allowable load of each type of flat glass

The wind pressure resistance strength of flat glass, to be exact, varies with the working time (evaluation time) of the wind pressure, the humidity etc. Strength in each glass thickness can be obtained from breaking test, which include these factors, on the practical window size glasses. The average failure load and allowable load in each glass thickness in Table-1 have been obtained statistically from measured values of breaking of tens of glasses and their standard deviation. The average failure load (kg) and allowable load (kg) are obtained multiplying average failure wind pressure (kg/m<sup>2</sup>) or allowable wind pressure (kg/m<sup>2</sup>) by area of glass (m<sup>2</sup>)

The value obtained dividing the allowable load of area of glass becomes the allowable wind pressure (kg/m<sup>2</sup>). A failure probability of 1/1000 at an allowable load means that there is a probability in which one of 1000 sheets of glass will be broken if allowable load works on all the sheet of glass.

Table 1 Allowable Loads of Flat Glasses

Type	Ketebalan Kaca (mm)	Beban Rata-Rata (kg)	Beban Ijin (kg)
INDOFLOT PANASAP STOPSOL SUNERGY PLANIBEL G	2	225	90
	3	450	180
	4	650	260
	5	900	360
	6	1100	440
	8	2000	800
	10	2500	1000
	12	3000	1200
	15	4250	1700
FIGURED GLASS	2	225	90
	4	335	135
	6	660	265
TEMPERED GLASS	4	1950	780
	5	2700	1080
	6	3300	1320
	8	6000	2400
	10	7500	3000
	15	9000	3600
LAMINATED GLASS	3+3	625	250
	5+5	1350	540
	6+6	1800	720
	8+8	2875	1150
	10+10	4200	1680
	12+12	5750	2300
	15+15	8550	3420
19+19	13100	5245	

### Catatan

Beban rata-rata (kg) = Tekanan angin rata-rata (kg/m<sup>2</sup>) x Luas area kaca (m<sup>2</sup>)  
 Beban yang diizinkan (kg) = Tekanan angin yang diizinkan (kg/m<sup>2</sup>) x Luas area kaca (m<sup>2</sup>)

### Note

Average failure load (kg) = Average wind pressure (kg/m<sup>2</sup>) x Area of glass (m<sup>2</sup>)  
 Allowable load (kg) = Allowable wind pressure (kg/m<sup>2</sup>) x Area of Glass (m<sup>2</sup>)

## Perhitungan Kekuatan Kaca Terhadap Angin

Perhitungan ini khusus untuk kaca dengan 4 tumpuan (rangka pada 4 sisi kaca). Untuk kondisi lain silahkan menghubungi ASAHIMAS.

1. Luas kaca (A) = Luas bidang kaca bagian dalam rangka dalam m<sup>2</sup>
2. Posisi kaca (h) = Ketinggian titik tengah bidang kaca terhadap permukaan tanah dalam meter.
3. Tekanan angin (Q) = Tekanan yang bekerja pada permukaan kaca akibat angin dalam kg/m<sup>2</sup>

Penentuan harga Q:

$$Q = 60 \sqrt{h} \quad \text{dimana } h = \text{posisi kaca dari permukaan tanah, m. } h \leq 16 \text{ m}$$

$$Q = 120 \sqrt[4]{h} \quad \text{dimana } h > 16 \text{ m}$$

$$Q = \frac{V^2}{16} \quad \text{dimana } V = \text{kecepatan angin standard, m/dt}$$

$$Q = \frac{V^2}{17,4} \quad \text{dimana } V = \text{kecepatan angin besar (topan), m/dt}$$

4. Koefisien tekanan angin (C) = Angka yang menunjukkan berapa bagian dari tekanan angin bekerja pada permukaan kaca sebagai tekanan angin rencana.

Penentuan harga C:

- (i) C = 0.8 dimana tinggi bangunan < 31 m
- (ii) Untuk tinggi bangunan > 31 m, maka harga C ditentukan sebagai berikut:

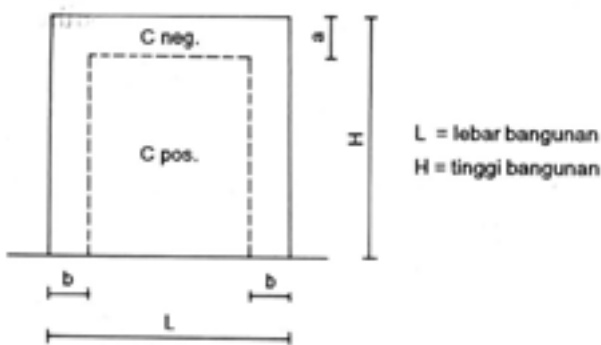

## Calculation of Glass Strength Against Wind Pressure

This calculation particularly for the strength of rectangular plate glass supported by its four sides and unloaded uniformly. For other condition please contact ASAHIMAS.

1. Area of glass (A) = Area of glass in frame in m<sup>2</sup>
2. Glass position (h) = The height center point of glass to the surface of the ground in m.
3. Velocity of wind (Q) = Some pressure is generated on the glass plate by the movement of air kg/m<sup>2</sup>

Obtain Q:

$$Q = 60 \sqrt{h} \quad \text{When } h \text{ is } 16 \text{ m or below, } h \leq 16 \text{ m}$$

$$Q = 120 \sqrt[4]{h} \quad \text{When } h > 16 \text{ m}$$

$$Q = \frac{V^2}{16} \quad \text{When } V \text{ is normal wind velocity in m/dt}$$

$$Q = \frac{V^2}{17,4} \quad \text{When } V \text{ is unnormally wind velocity (taifun) in m/dt}$$

4. Coefficient of wind force (C) = The ratio of conversion. How many the air flow is converted into pressure.

Obtain C:

- (i) C = 0.8 when the building is 31 m height or lower
- (ii) When the building height exceeds 31 m, C must be determined as below:

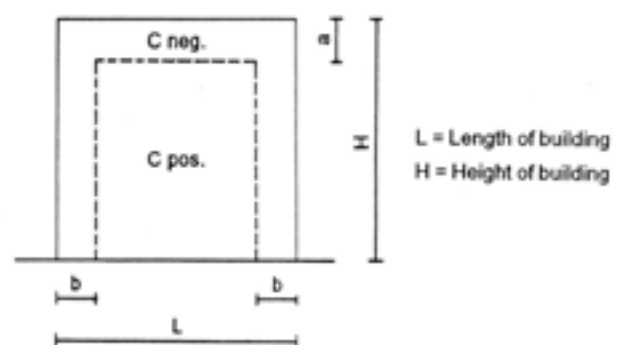

Table 2 Value of C

Building Ratio (L/H)	a	b	C Pos	C Neg
0.1 < L/H < 0.2	H / 15	L / 6	1.0	-1.5
0.2 < L/H < 0.4	H / 10	L / 8	0.9	-1.5
0.4 < L/H < 0.4	H / 6	L / 10	0.8	-1.5

5. Tekanan Angin Rencana (P) = Tekanan angin yang direncanakan akan bekerja pada permukaan kaca, kg/m<sup>2</sup>  
 Penentuan harga P : P = C x Q  
**Catatan:**  
 Karena cara perhitungan tekanan angin rencana berbeda untuk setiap negara, maka ikutilah perhitungan standard masing-masing negara untuk perhitungan ini.
6. Beban izin rencana (W) = Beban yang direncanakan akan bekerja pada satu satuan luas permukaan kaca , kg.  
 Penentuan harga W : W = P x A
7. Tebal kaca (t) = Ketebalan kaca yang diperoleh berdasarkan perhitungan kekuatan kaca terhadap angin, mm. Melalui tabel-1, maka dengan syarat W < beban izin, maka diperoleh ketebalan kaca sesuai dengan jenis kaca yang akan digunakan.
8. Untuk mengetahui seberapa jauh keamanan yang diperoleh dari perhitungan di atas dapat dihitung melalui rumus dan tabel berikut:

Untuk kaca tunggal:

$$P = \frac{K}{F.A} \left( t + \frac{t^2}{4} \right) \rightarrow F = \frac{K}{P.A} \left( t + \frac{t^2}{4} \right)$$

- Dimana F = Faktor keamanan  
 K = Konstanta kaca tunggal  
 P = Tekanan angin rencana, kg/m<sup>2</sup>  
 A = Luas kaca, m<sup>2</sup>  
 t = Tebal kaca, mm

Untuk kaca Lamisafe:

$$F = \frac{K1}{P.A} \left( t^2 + \frac{t2^2}{4} \right) \left[ 1 + \left( \frac{t1}{t2} \right)^3 \right]$$

- Dimana K1 = Konstanta kaca Lamisafe = 24  
 t1 = Ketebalan kaca tipis, mm  
 t2 = Ketebalan kaca tebal, mm

Table 3 Value of K

Type	Thickness (mm)	K	
INDOFLOT PANASAP STOPSOL SUNERGY PLANIBEL G	2	80	
	3		
	4		
	5		
	6		
	8		
	10		
FIGURED	12	70	
	15		
	19		
	2		45
	4		
6			

5. Design Wind Pressure (P) = The wind pressure to be applied to a glass, kg/m<sup>2</sup>  
 Obtain P : P = C x Q  
**Note:**  
 As the calculation methods of design pressure differ by country, follow the standards of each country for the calculation.
6. Design load (W) = Design load applied to area of glass, kg.  
 Obtain W : W = P x A
7. Glass Thickness (t) = The thickness of the glass is determined by table-1, when the design load of the glass will be less than the allowable load (WA)
8. The equation below can be applied approximately to the relationship among wind pressure, glass area, glass thickness, and a safety factor on the basis of wind pressure breaking test results:  
 For single-glass:

$$P = \frac{K}{F.A} \left( t + \frac{t^2}{4} \right) \rightarrow F = \frac{K}{P.A} \left( t + \frac{t^2}{4} \right)$$

- Where F = Safety factor  
 K = A constant value specific to single glass  
 P = Allowable wind pressure, kg/m<sup>2</sup>  
 A = Area of glass (m)  
 t = Glass thickness (mm)

For Laminated Glass:

$$F = \frac{K1}{P.A} \left( t^2 + \frac{t2^2}{4} \right) \left[ 1 + \left( \frac{t1}{t2} \right)^3 \right]$$

- Where K1 = 24  
 t1 = Thickness of thin glass (mm)  
 t2 = Thickness of thick glass (mm)

Table 4 Safety Factor and Failure Probability

Safety Factor	Failure Probability
1.0	0.5
1.5	0.09
2.0	0.01
2.5	0.001
3.0	0.0001
3.3	0.00003

# 5. IMPACT STRENGTH AND SAFETY

Kaca sebagai bahan bangunan, memiliki banyak sifat istimewa seperti transparan, tahan cuaca, tidak mudah terbakar, tidak terkikis dan sebagainya. Tapi ada satu hal yang perlu diperhatikan yaitu kekuatannya terhadap benturan. Benturan yang dapat membuat kaca pecah tergantung pada berat, bentuk, kekerasan dan kecepatan benturan.

Glasses have many excellent features, transparency, weather resistance, uncombustible, etc. as building materials. But it does need an extra attention on the strength, especially when striking against anything. A strike that would break a glass is depending on the weight, size, hit pressure, speed of striking and the variety of glass breaking depends on the type of glass itself.

Table 1 Mechanism of Breaking and Probable Objects

Breaking by Bending	
Mechanism of Breaking ———→ Tensile Stress - - - - -→ Compression Stress	
Probable Objects	Collision of Human Body Balls Collision of Fairly Hard Objects
Breaking by Concentrated Stress	
Mechanism of Breaking ←—— Tensile Stress - - - - - Compression Stress	
Probable Objects	Bullets Impact by Sharp Objects Steel Balls Stones Collision of Hard Objects

Table 2 Rank of Safety



\* Falling Ball and Weight Impact Strength (Mean Breaking Height)

Table 3 Mean Breaking Strength of Flat Glass

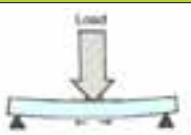
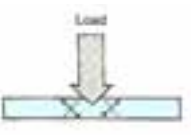
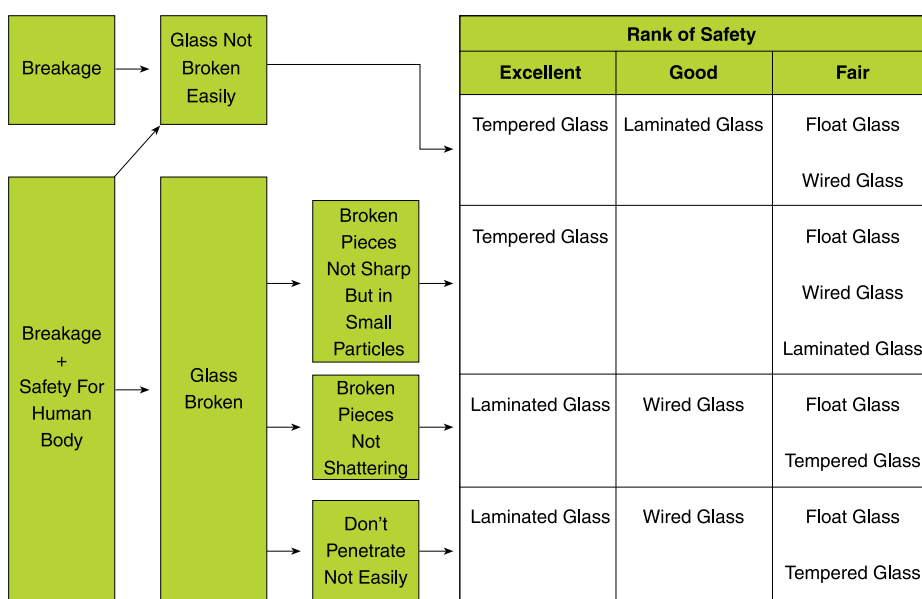
Type	Thickness (mm)	Type of Ball	Steel Ball		Rubber Weight (Area 10 cm <sup>2</sup> )			
			Weight of Balls	130 g	225 g	130 g	450 g	2000 g
Float Glass	2			55 cm	18 cm	140 cm		
	3			110	36	165		
	5			135	45	305		
	6			145	50	385		
	8			160	55		350	
	12			240	80		515	
Processed Glass	Tempered Glass 6				370			
	Tempered Glass 8				520		278	
	Tempered Glass 12				650		755	

\* Thermal Impact Strength (Quenching Strength)

Table 4 Thermal Impact Strength of Flat Glass

Type (mm)	Thickness (mm)	Rubber Weight (Area 10 cm <sup>2</sup> )	
		Breaking 0%	Breaking 100%
Float Glass	2	100° C	140° C
Float Glass	3	80	120
Float Glass	5	60	100
Tempered Glass	5	170	220
Tempered Glass	8	170	220
Tempered Glass	12	150	200

Drop square specimens of 7x7 cm in water (0°C) Cut off edges with a cutter.



# 6. GLASS BALUSTRADE - SS SYSTEM



## Karakteristik Umum

Sistem balustrade ini menggunakan sealant secara maksimal untuk semua sambungan dan pendukungnya, tanpa menggunakan baut sama sekali.

Sistem ini sangat sederhana, mudah dalam pemasangan dan penggantian kaca, terlihat bersih dan sangat ekonomis. Tanpa menggunakan baut, berarti tanpa ada lubang pada kaca sehingga kekuatan kaca menjadi maksimal tanpa ada gangguan.

## Catatan

Gunakan handrail pada sekeliling tepi kaca untuk melindungi tepi kaca dari benturan langsung.

Kaca yang digunakan dalam system ini adalah Tempered 12 mm atau Laminated Tempered 12 mm dan 16 mm, dengan bahan pendukung sebagai berikut:

- Bulking agent : Gypsum khusus (tipe 450)
- Balok perletakan : Karet neoprene
- Bahan pendukung : Karet neoprene berongga
- Bahan penyekat : Silikon netral (hindari yang bersifat asam)

## Perhitungan Kekuatan terhadap Tekanan

### ● Perhitungan Beban Izin (Pa)

$$Pa = \frac{500 \times Z}{H}$$

$$M = P \times H$$

$$\delta = \frac{M}{Z} = \frac{P \times H}{Z}$$

- Dimana
- Pa : Beban izin per 1 m lebar kaca (kg)
  - M : Momen kelengkungan (kg.cm)
  - $\delta$  : Gaya tekan(kg/cm<sup>2</sup>) = 500 kg/cm<sup>2</sup> untuk tempered glass
  - P : Beban per 1 m lebar kaca (kg)
  - H : Tinggi balustrade (cm)
  - Z\* : Section modulus (cm<sup>3</sup>/m) (per 1 m lebar kaca)

\* Lihat tabel - 1

### ● Perhitungan Lendutan

$$\delta_{max} = \frac{P \times h^3}{Z}$$

- Dimana
- E : Modulus Young (72 x 10<sup>4</sup> kg/cm<sup>2</sup>)
  - I\* : Momen kedua dari luar kaca (cm<sup>4</sup>/m) (per 1 m lebar kaca)

\* Lihat tabel - 1

## Features

*Glass Balustrade – SS System is specially developed and secured using sealant joint & sealant support without conventional bolting systems.*

*Very simple, short term time for installation, easier to replace, more economical, and better performance.*

*Without conventional bolting, means no drilling and notching on the glass, such as the strength of glass is maximized.*

## Notes

*Always install a rigid handrail top of glass baluster to protect the edged and prevent individual deformation.*

*Glass used for this Balustrade-SS System is tempered glass of 12 mm thickness, laminated tempered glass of 12 mm or 16 mm thickness, with supporting materials:*

- Bulking agent : Special type of Gypsum (type 450)*
- Setting block : Neoprene rubber*
- Backup material : Hollow neoprene rubber*
- Sealing material : Neutral silicon sealant (avoid the acetic acid during type)*

## Calculation of Pressure Resistance Strength

### ● Calculation of allowable load (Pa)

$$Pa = \frac{500 \times Z}{H}$$

$$M = P \times H$$

$$\delta = \frac{M}{Z} = \frac{P \times H}{Z}$$

- Where
- Pa : Allowable load per 1 mm width of glass (kg)
  - M : Bending moment (kg.cm)
  - $\delta$  : Stress (kg/cm<sup>2</sup>) = 500 kg/cm<sup>2</sup> for Tempered glass
  - P : Load per 1 m width of glass (kg)
  - H : Balustrade height (cm)
  - Z\* : Section modulus (cm<sup>3</sup>/m) (per 1 m width of glass)

\* Refer to the Table - 1

### ● Perhitungan Lendutan

$$\delta_{max} = \frac{P \times h^3}{Z}$$

- Where
- E : Young's modulus (72 x 10<sup>4</sup> kg/cm<sup>2</sup>)
  - I\* : Second moment of area (cm<sup>4</sup>/m) (per 1 m width of glass)

\* Refer to the Table - 1

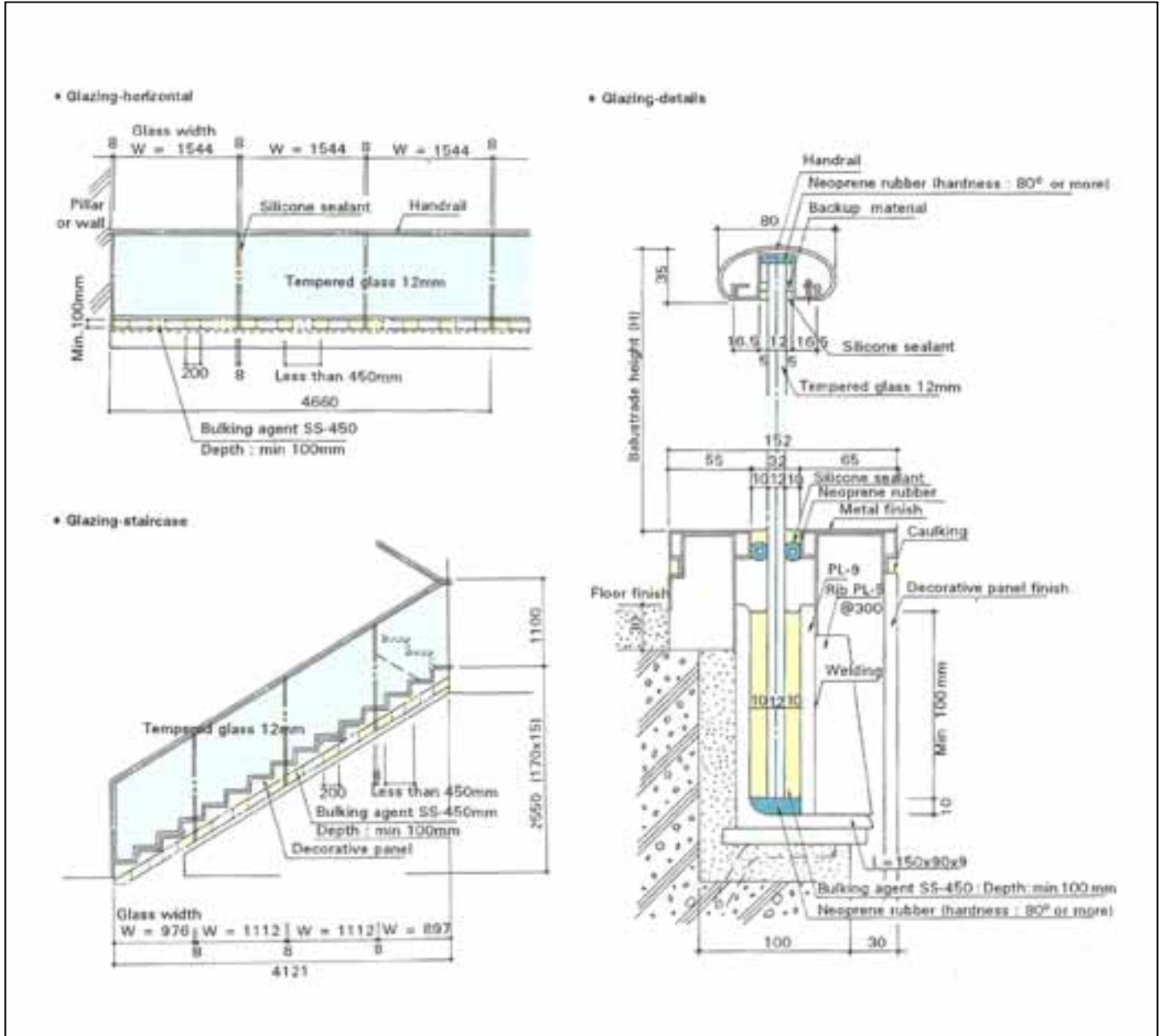

Table 1 Values of Z and I (Per 1 m Width of Glass)

Factor	Second Moment of Area (I)	Section Modulus (Z)
Laminated Tempered Glass 12 mm (6+6)	7.0 cm <sup>4</sup> /m	14.4 cm <sup>3</sup> /m
Tempered Glass 12 mm	14.4	24.0
Laminated Tempered Glass 16 mm (8+8)	17.0	25.6

Table-2 Summarizes the Calculated Results

Glass Type	Allowable Load (Pa) (Per 1 m Width of Glass)		
	Laminated Tempered Glass 12mm (6+6)	Tempered Glass 12mm	Laminated Tempered Glass 12mm (6+6)
Balustrade Height (h)cm			
70	100 kg	170 kg	180 kg
80	90	150	160
90	80	130	140
100	70	120	130
110	65	110	120
120	60	100	105
130	55	90	95
140	50	85	90
150	50	80	85

Table-3 Load by Body

Action	Load	Maximum (kg)	Average (kg)
Leaning Forward		18	9.9
Leaning Backward		13	8.1
Pushing		107	73.5
Pulling		99	79.0
Pushing by Running		127	67.4
Pushing by The Shoulder		71	36.3





# 7. SOUND INSULATION

## Transmission Loss of Flat Glass

Table 1 Transmission Loss of Flat Glass

Type	Thickness (mm)	Transmission Loss (dB)		Coincidence Frequency (Hz)
		Mean T.L	STC	
Single Flat Glass	3	26	26	4250
	4	27	27	2880
	5	28	30	2530
	6	29	31	2020
	6.8	30	32	1760
	8	31	32	1500
	10	33	33	1190
	12	34	34	1010
	15	36	34	790
19	36	33	620	
(Laminated Glass)	6 (3+0.75+3)	31	33	2740
	10 (5+0.75+5)	35	37	1580
	12 (6+0.75+6)	37	38	1450

**Catatan**

Diukur oleh Institut Riset Fisika Kobayasi  
 Dimensi Kaca : 1700 x 1300 mm  
 Beban untuk setiap unit area dinding adalah 270 kg/cm<sup>3</sup>

**Catatan**

TC : Transmisi Hilang  
 STC : Koefisien Transmisi Suara

Table 3 Mean Transmission Losses of Other Materials For Reference

Materials	Thickness & Composition (mm)	Mean Transmission Loss (dB)
Lauan Plywood	3	14
Insulation Board	12	19
Asbestos Slate	6.5	23
Lauan Plywood Wall	57	23
	(Lauan Plywood 6 + Air Layer 45 + Lauan Plywood 6 Gap Between Stud and Furring Strip 450)	
Gypsum Plaster Board	9	26
Glass Block Wall	95	40
Concrete Block Wall	180	44
	(Mortar 15 + Concrete Block 150 + Mortar 15)	
Concrete Floor	145	55
	(Concrete 100 + Ceiling Base 19 + Lath Board 13 + Plaster 13)	

**Note**

Measured by Kobayasi Institute of Physical Research  
 Glass dimensions: 1700 x 1300 mm  
 Mass per unit area of filler wall is about 270 kg/cm<sup>2</sup>

**Note**

T.C. : Transmission Loss  
 S.T.C. : Sound Transmission Coefficient

Table 2 Transmission Loss of Flat Glass at Each Frequency

Type (mm)	Frequency (Hz)	Unit (dB)																	
		100	125	160	200	250	315	400	500	630	800	1000	1250	1600	2000	2500	3150	4000	5000
Single Flat Glass	FL3	10	20	19	19	20	22	25	25	26	28	30	31	32	33	34	32	22	26
	FL4	13	22	21	22	22	24	25	27	29	30	32	32	33	34	32	23	27	31
	FL5	15	23	23	23	23	26	27	28	30	31	33	34	34	33	26	27	29	33
	FL6	15	24	24	24	25	27	28	30	32	33	34	34	33	27	28	30	34	37
	FL8	17	26	26	26	27	29	30	32	33	35	35	30	28	30	33	37	40	42
	FL10	19	28	28	28	29	30	33	34	35	35	33	29	32	34	38	40	44	47
	FL12	21	30	29	30	29	32	33	34	35	34	29	32	36	38	40	43	47	50
	FL15	22	30	31	31	30	34	34	35	35	28	30	35	38	42	44	45	49	52
	FL19	22	30	31	32	32	35	35	34	28	27	32	36	39	44	46	48	50	52
(Laminated Glass)	PL6(FL3+0.75+FL3)	18	26	25	25	25	28	29	30	33	34	34	35	35	33	33	34	38	42
	PL10(FL5+0.75+FL5)	22	29	29	28	30	32	34	35	36	37	36	35	35	37	40	43	47	49
	PL12(FL6+0.75+FL6)	23	29	31	30	31	34	35	36	37	37	35	35	37	40	42	46	49	53

